



Home2 - Dynamic FF&E Specifications Public Areas

Version 3.0 March 2023

Revised May 2023

Revised June 2023

HILTON 755 CROSSOVER LANE, MEMPHIS, TENNESSEE 38117



Summary of Changes Public Area Dynamic Specifications

Date	Item Number	Description
May-23 Δ1	PA-100, PA-101, PA-108, PA-112, PA-305, PA-312, PA-313, PA-400, PA-401, PA-402	Product Information Updates
	PA-203, PA-206, PA-502, PA-505, OF-701, OF-704, OF-709, OF-712	Vendor Contact Update
	PA-201, PA-202, PA-204, PA-205, PA-300, PA-301, PA-302, PA- 303, PA-306, PA-307, PA-309, PA-500, PA-501, PA-503, PA- 504, OF-700, OF-708, OF-713, OF-716	Product Information Updates, Vendor Contact Update
	PA-113, PA-150, PA-250, PA-350, PA-351, PA-450, PA-550, PA- 850, PA-851, OF-718	New Specifications Added
	PA-200	Product Deleted
Jun-23 Δ2	PA-506, OF-719	New Specification Added
	PA-308, PA-314, PA-315, PA-400, PA-401, PA-402 PA-500, OF-715, OF-716, OF-717, PA-350, PA-351, PA-850, PA-851	Specification Information Updates
	PA-313	Additional Suppliers
	OF-713, OF-714,	Vendor Contact Update

Table of Contents

Summary of Changes 2

 Table of Contents 3

 Introduction 4

Supplemental Information 5

 Index by Area 6

 Seating (100 series) 9

 Lighting (200 series) 39

 Casegoods (300 series) 50

Window Treatment (400 series) 84

 Art & Mirrors (500 series) 90

 Outdoor (700 series) 102

 Millwork (800 series) 139

Index of Renovation Specs 155

 Renovation Specs 156

Introduction

The Home2 Suites Vibrant and Dynamic prototypical décor packages have been thoughtfully designed by Hilton to align with the current North American prototype and provide a complete décor solution. The vendors and their products were chosen through an extensive sourcing process and represent a high-quality, economical, and streamlined solution for a Home2 Suites Brand property. If used holistically, the package with the specified vendors is pre-approved and will help expedite project approvals and procurement. Refer to Project HUB for submittal requirements.

Within this document are the FF&E specifications needed to implement the Home2 Suites Dynamic prototypical décor scheme for the public area. Along with the Design Guide, the Renovation Guide, the Home2 Suites Brand Standards, and the Architectural Prototype Drawings, these specifications and the corresponding guest suites and finish specifications will assist the Owner/Designer in completing either a new build or renovation Home2 Suites Brand property.

Supplemental specifications unique to soft goods renovations will be provided in a forthcoming release.

To promote a reliable guest experience, the specified design and vendors are **REQUIRED** for the PA-100 Central Banquette. Finishes and fabrics for this required item may be customized. The form may not be modified, except for dimension adjustments as needed to fit the dimensions of the room.

Partial or complete customization of non-required specifications is permitted. Any custom designs, specifications, finishes, or vendors **MUST** be submitted for review and approval.

If there are any questions about how to use this document, please contact Architecture, Design & Construction at design.review@hilton.com.

Submit all custom specifications to Hilton Design Review (projecthub.hilton.com) for final approval prior to purchasing or implementation of any material.

Negotiated pricing is available through Hilton Supply Management. Connect with the HSM team of procurement experts at HSMx@Hilton.com to learn more about implementing the benefits of pre-approved packages.

Supplemental Information

The below documents can be found on the designinformation.hilton.com (username and password are hilton20xx, where xx is current year).

- **Design Guide:** This document gives a designer all the reasons why the Brand is what it is. It helps establish uniformity of practice, consistently express the Brand identity and serves as a guide for Interior Design and FF&E selection. It discusses the specific elements required and describes how the design is integrated to optimize guest experience and operational efficiency.
- **Renovation Guide:** This document provides tools for implementing the current Home2 Suites design in a renovation.
- **Home2 Suites Brand Standards:** This document lists the minimum standards, procedures, rules, regulations, policies, and techniques required by the Home2 Suites Brand and Hilton.

Vendors

- **Approved Vendors:** Vendors specified herein as manufacturers are pre-approved and have been selected through an extensive sourcing, product development, and vetting effort. Approved Vendors have the necessary experience with the specified products, including pre-approved shop drawings, finishes, and model room samples. Approved Vendors have committed to ensuring all products meet or exceed Home2 Suites Brand Standards and upholding Hilton's Responsible Sourcing Policy.
- **Required Vendors:** Vendors specified herein as manufacturers for the PA-100 Central Banquette are approved and required. Alternate vendors may not be substituted for this item.
- For custom designs on non-required items, Owners/Designers are encouraged to use the Approved Vendors based on their experience with the Home2 Suites Brand Standards and prototype. An Owner/Designer may use a vendor of their choice for non-required items outside of the Approved Vendors. However, those vendors and each of their products must be approved through the Hilton Design Review process on an individual project basis. It is the Owner's/Designer's responsibility to ensure that all such products comply with Home2 Suites Brand Standards.

Notes

- All upholstered specifications are fabric-inclusive when using the Approved Vendors within the Home2 Suites prototype package. Upholstered products may be purchased with COM fabric, subject to approval through the Hilton Design Review process.
- It is the Owner's/Designer's responsibility to maintain the design intent and adapt all required elements to their property's conditions and code requirements prior to fabrication and installation.

Index

Project Name: Home2 FF&E Specs

Scheme: Dynamic-Scheme B

Area: Public Area

Issue Date	Revision #	Item Number	Item Description
<u>Seating</u>			
03/31/23	Δ1	(B) PA-100	Central Banquette - REQUIRED VENDOR/DESIGN
03/31/23	Δ1	(B) PA-101	Dining Chair @ 2 Top Square Table
03/31/23		(B) PA-102	Dining Chair @ Banquette
03/31/23	Δ2	(B) PA-103	Lounge Chair @ Banquette
03/31/23		(B) PA-104	High Back Lounge Chair
03/31/23		(B) PA-105	Focus Booth
03/31/23		(B) PA-106	Dining Chair @ 4 Top Table
03/31/23		(B) PA-107	Counter Stool @ Perch Table
03/31/23	Δ1	(B) PA-108	Single Sofa @ TV Lounge
03/31/23		(B) PA-109	Counter Stool @ Laundry Room
03/31/23		(B) PA-110	Employee Breakroom Chair
03/31/23		(B) PA-111	Meeting Room Stack Chair
03/31/23	Δ1	(B) PA-112	Task Chair
05/01/23		(B) PA-113	Large Sofa @ TV Lounge
<u>Lighting</u>			
03/31/23	Δ1	(B) PA-200	Task Light @ Central Banquette
03/31/23	Δ1	(B) PA-201	Pendant Lighting @ Focus Booth
03/31/23	Δ1	(B) PA-202	Bathroom Vanity Light
03/31/23	Δ1	(B) PA-203	Floor Lamp @ TV Lounge
03/31/23	Δ1	(B) PA-204	Wall Sconce @ Guest Corridor
03/31/23	Δ1	(B) PA-205	Pendant Lighting @ Reception
03/31/23	Δ1	(B) PA-206	Table Lamp @ TV Lounge
<u>Casegoods</u>			
03/31/23	Δ1	(B) PA-300	Square 2 Top Dining Table
03/31/23	Δ1	(B) PA-301	Round 2 Top Dining Table
03/31/23	Δ1	(B) PA-302	Rectangular 4 Top Dining Table
03/31/23	Δ1	(B) PA-303	Tea Height Round Table @ High Back Lounge Chair
03/31/23		(B) PA-304	Laptop Table
03/31/23	Δ1	(B) PA-305	Square Side Table @ TV Lounge
03/31/23	Δ1	(B) PA-306	Dining Table @ Booth
03/31/23	Δ1	(B) PA-307	ADA Dining Table
03/31/23	Δ2	(B) PA-308	Media Credenza @ TV Lounge
03/31/23	Δ1	(B) PA-309	Breakroom Dining Table @ Employee Breakroom
03/31/23		(B) PA-310	Towel Station @ Fitness
03/31/23		(B) PA-311	Food Delivery Pick-Up Console
03/31/23	Δ1	(B) PA-312	Meeting Room Conference Table
03/31/23	Δ2	(B) PA-313	Meeting Room Training Table

Index

Project Name: Home2 FF&E Specs

Scheme: Dynamic-Scheme B

Area: Public Area

Issue Date	Revision #	Item Number	Item Description
03/31/23	Δ2	(B) PA-314	Retail Table - Large (Market Table)
03/31/23	Δ2	(B) PA-315	Retail Table - Small (Market Table)
03/31/23		(B) PA-316	Retail Display System

Window Treatment

03/31/23	Δ2	(B) PA-400	Roller Shade @ Lobby & Fitness Room (Curtain Wall)
03/31/23	Δ2	(B) PA-401	Roller Shade @ Fitness (Framed Windows) & Breakroom
03/31/23	Δ2	(B) PA-402	Roller Shade @ Sales, Boardroom, & Meeting Room

Artwork & Mirrors

03/31/23	Δ2	(B) PA-500	TV Lounge Artwork
03/31/23	Δ1	(B) PA-501	Decorative Mirror @ Guest Elevator Lobbies
03/31/23	Δ1	(B) PA-502	Bathroom Mirror
03/31/23	Δ1	(B) PA-503	Meeting Space Artwork
03/31/23	Δ1	(B) PA-504	Boardroom Artwork
03/31/23	Δ1	(B) PA-505	Guest Engagement Wall Artwork
06/23/23		(B) PA-506	Fitness Wall Hooks

Outdoor

03/31/23	Δ1	(B) OF-700	Bench Seating @ Outdoor Lounge
03/31/23	Δ1	(B) OF-701	Bench Seating @ Outdoor Lounge Firepit
03/31/23		(B) OF-702	Arm Chair @ Outdoor Lounge
03/31/23		(B) OF-703	Lounge Chair @ Outdoor Lounge Firepit
03/31/23	Δ1	(B) OF-704	Ottoman @ Outdoor Lounge Firepit
03/31/23		(B) OF-705	2 Top Table @ Outdoor Lounge & Grilling Patio
03/31/23		(B) OF-705-ADA	ADA Table @ Grilling Patio
03/31/23		(B) OF-706	Food Prep Table @ Grilling Patio
03/31/23		(B) OF-707	Cocktail Table @ Outdoor Lounge
03/31/23	Δ1	(B) OF-708	Lounge Chair @ Outdoor Lounge
03/31/23	Δ1	(B) OF-709	Round Side Table @ Outdoor Lounge
03/31/23		(B) OF-710	Counter Stool @ Grilling Patio
03/31/23		(B) OF-711	Dining Chair @ Outdoor Lounge, Grilling Patio, & Pool
03/31/23	Δ1	(B) OF-712	Counter Height Table @ Grilling Patio
03/31/23		(B) OF-713	Chaise Lounge @ Pool
03/31/23	Δ2	(B) OF-714	Round Side Table @ Pool
03/31/23	Δ2	(B) OF-715	Round 2 Top Table @ Pool
03/31/23	Δ2	(B) OF-716	Planter
03/31/23	Δ2	(B) OF-717	String Lights @ Outdoor Lounge & Grilling Patio
03/31/23		(B) OF-717.1	Light Bulbs @ String Lights
05/01/23		(B) OF-718	Bench Seating @ Grilling Patio

Home2 - Dynamic FF&E Specifications



Index

Project Name: Home2 FF&E Specs

Scheme: Dynamic-Scheme B

Area: Public Area

Issue Date	Revision #	Item Number	Item Description
6/23/2023		(B) OF-719	4 Top ADA Dining Table

Millwork

03/31/23	(B) PA-800	Perch Table
03/31/23	(B) PA-801	Reception Desk
03/31/23	(B) PA-802	Breakfast Servery
03/31/23	(B) PA-803	Coffee & Hydration Station
03/31/23	(B) PA-804	Trash & Recycling
03/31/23	(B) PA-805	Guest Laundry Table
03/31/23	(B) PA-806	One Bay Boardroom Casework
03/31/23	(B) PA-807	Three Bay Meeting Room Casework

Project Name: Home2 Prototype FF&E Specifications
 Scheme: B-Dynamic
 Issue Date: March-23
 Revisions: May-23 Δ1

Item Number: **(B) PA-100**
 Item Name: Central Banquette - **REQUIRED**
 Area Name: Public Area - Lobby

Manufacturer:	Brookline	Edgecombe Furniture	Southfield Furniture
Address:	4015 Cheyenne Dr. Archdale, NC 279263	310 Staton Rd Greenville, NC 27834	2224 Shore Street High Point, NC 27263
Phone:	901-482-6951	252-689-6847	336-434-6220
Contact:	Bill Cotter	Jenna James	Michael Gulledge
E-mail:	Bill@Brooklinefurniture.com	jjames@cottonbeltinc.com	MichaelGulledge@southfieldfurniture.com
Web:	www.brooklinefurniture.com	www.edgecombe.com	www.southfieldfurniture.net

Description: Central Banquette
 Material/Finish: Seat/Back: COM
 Top Deck and Base: Plastic laminate to match PL-01
 Wilsonart 5th Ave Elm 7966K-12 Soft Grain Texture

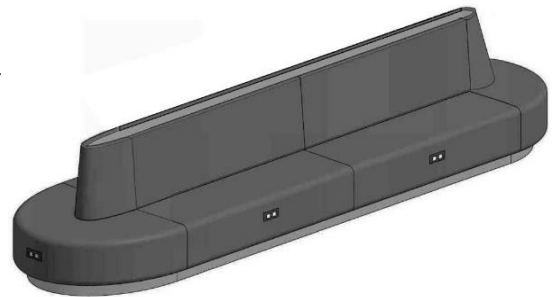

Overall Dimensions: 198"W x 52"D x 44"H
 Arm Height: NA
 Seat Height: 18"
 Seat Depth: 18"
 Seat Cushion Style: Semi-Attached, Removable
 Back Cushion Style: Semi-Attached, Removable
 Cushion Content: All foam, filling and Dacon wrap shall be fire retardant to meet all applicable codes. Must pass NFPA 260/CAL117

Back COM:
 Manufacturer: P Kaufmann Contract
 Pattern: Pixel
 Color: 004M Sonoma
 Finish: SSR
 Fire Rating: CAL 117-2013 NFPA 260
 Content: 94% Polyester, 6% modacrylic
 Width: 54"
 Repeat: NA
 Double Rubs: 100,000
 Backing: Acrylic
 Railroad: No



Back

Seat COM:
 Manufacturer: Fil-Doux
 Pattern: Brussels
 Color: Denim SKU110132
 Finish: Pro-Tech
 Fire Rating: CAL 117-2013 NFPA 260 Class 1, IMO Inherent
 Content: 100% Otratex
 Width: 54"
 Repeat: NA
 Double Rubs: 200,000
 Backing: 100% Recycled polyester knit
 Railroad: No



Seat



PL-01

Notes: Provide blocking under removable top deck for future attachment of light fixtures.



Project Name: Home2 Prototype FF&E Specifications
Scheme: B-Dynamic
Issue Date: March-23
Revisions: May-23 Δ1

Item Number: **(B) PA-100**
Item Name: Central Banquette - **REQUIRED**
Area Name: Public Area - Lobby

Data/Electrical: (6) Mini/multimedia hub (black finish) mounted in upholstered seat (refer to drawings) with (2) standard outlets and (2) USB ports. Coordinate light fixture (PA-200) with drawings.

REQUIRED VENDOR, REQUIRED DESIGN

Instructions:

- All quantities to be verified by hotel operator prior to purchasing.
- It is the responsibility of the owner to interpret these specifications for each property.
- All interpretations of the specification **MUST** be submitted to Hilton Design Review (projecthub.hilton.com) for final approval prior to purchasing or implementation of any material.
- Must be of contract quality and suitable for commercial use.
- COM quantities must be verified by fabricator prior to ordering.
- All materials and methods of construction must comply with all local fire and life safety codes for use in hotels and other public spaces, and Home2 Brand Standards.
- All internal hardware (hinges, screws, bolts, etc.) shall be corrosion proof.
- Wood frames to be certified sustainable sources. All stress joints to be connected by double doweled, screwed and glued corner reinforcement.
- Manufacturer to provide nylon carpet glides when applicable.
- All foam, batting, padding, and Dacron wrap shall be fire retardant to meet all applicable codes.
- Cushions to be adequately vented for displacement of air and to provide increased comfort.
- Ensure that upholstered goods will fit in elevators and through doors prior to commencing fabrication.
- Entire frame and upholstery shall be inspected during the manufacturing and again after final assembly. Tailoring shall be neat, trim and performed in a professional manner.
- Manufacturer to clearly mark each carton with item ID and specification number.
- Manufacturer to verify all necessary parts, hardware with each item.

Project Name: Home2 Prototype FF&E Specifications
 Scheme: B-Dynamic
 Issue Date: March-23
 Revisions: May-23 Δ1

Item Number: **(B) PA-101 Supplier A**
 Item Name: Dining Chair @ 2 Top Square Table
 Area Name: Public Area - Lobby

Manufacturer: **ISA**
 Address: 46 Dufflaw Rd.
 Toronto, ON M6A 2W1 Canada

Phone: 416-782-9100 ext. 229
 Contact: Erik Esteves
 E-mail: erik@havaseat.com
 Web: www.havaseat.com

Description: Wood Dining Chair with Upholstered Seat and Wood Back
 Model Name: Gustav 209-USP/UBP
 Material/Finish: Seat/Back COM, Solid wood stained to match (PL-02) Wilsonart High Line 7970K-18 Linearity Finish with Aeon, 20% sheen level
 Dimensions: 19.5"W x 21.5"D x 32"H
 Arm Height: NA
 Seat Height: 18"
 Seat Cushion Style: Attached tight upholstered cushion
 Back Cushion Style: Solid wood
 Cushion Content: All foam, filling and Dacon wrap shall be fire retardant to meet all applicable codes. Must pass NFPA 260/CAL117.
 COM/COL: Manufacturer: P Kaufmann Contract
 Pattern: Laney PVC
 Color: Custom Cadet
 Finish: Pro Tech
 Fire Rating: CAL TB 117-2013 NFPA 260
 Content: 100% Polyester
 Width: 54"
 Repeat: NA
 Double Rubs: 200,000
 Backing: Polyester
 Railroad: No
 Notes: Heavy duty nylon glides

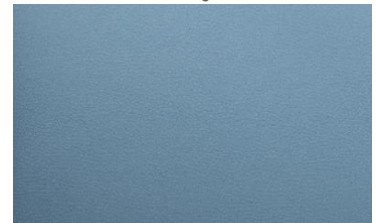

PL-02

Unless Using A Specified Manufacturer, Submit The Following Required Item(s) for Approval Prior to Fabrication:

Finish Sample **Cutting** **Shop Drawing**

Manufacturer to confirm the Product meets Hilton Design and Construction Standards as noted in Section 2515.00

Instructions:

- All quantities to be verified by hotel operator prior to purchasing.
- It is the responsibility of the owner to interpret these specifications for each property.
- All interpretations of the specification MUST be submitted to Hilton Design Review (projecthub.hilton.com) for final approval prior to purchasing or implementation of any material.
- Must be of contract quality and suitable for commercial use.
- COM quantities must be verified by fabricator prior to ordering.
- All materials and methods of construction must comply with all local fire and life safety codes for use in hotels and other public spaces, and Home2 Brand Standards.
- All internal hardware (hinges, screws, bolts, etc.) shall be corrosion proof.



Project Name: Home2 Prototype FF&E Specifications
Scheme: B-Dynamic
Issue Date: March-23
Revisions: May-23 Δ1

Item Number: **(B) PA-101 Supplier A**
Item Name: Dining Chair @ 2 Top Square Table
Area Name: Public Area - Lobby

-
- Wood frames to be certified sustainable sources. All stress joints to be connected by double doweled, screwed and glued corner reinforcement.
 - Manufacturer to provide nylon carpet glides when applicable.
 - All foam, batting, padding, and Dacron wrap shall be fire retardant to meet all applicable codes.
 - Cushions to be adequately vented for displacement of air and to provide increased comfort.
 - Ensure that upholstered goods will fit in elevators and through doors prior to commencing fabrication.
 - Entire frame and upholstery shall be inspected during the manufacturing and again after final assembly. Tailoring shall be neat, trim and performed in a professional manner.
 - Manufacturer to clearly mark each carton with item ID and specification number.
 - Manufacturer to verify all necessary parts, hardware with each item.

Project Name: Home2 Prototype FF&E Specifications
 Scheme: B-Dynamic
 Issue Date: March-23
 Revisions: May-23 Δ1

Item Number: **(B) PA-101 Supplier B**
 Item Name: Dining Chair @ 2 Top Square Table
 Area Name: Public Area - Lobby

Manufacturer: **Sandler**
 Address: 1201 Peachtree St NE Suite 1625
 Atlanta, GA 30361

Phone: 904-962-1137
 Contact: Kati Schoene
 E-mail: kati@sandlerseating.com
 Web: www.sandlerseating.com

Description: Wood Dining Chair with Upholstered Seat and Wood Back
 Model Name: Model Name: Hellen SE 03
 Material/Finish: Seat/Back COM, Solid wood stained to match (PL-02) Wilsonart High Line 7970K-18 Linearity Finish with Aeon, 20% sheen level
 Dimensions: 21.7"W x 21.7"D x 32.5"H
 Arm Height: NA
 Seat Height: 18"
 Seat Cushion Style: Attached tight upholstered cushion
 Back Cushion Style: Solid wood
 Cushion Content: All foam, filling and Dacon wrap shall be fire retardant to meet all applicable codes. Must pass NFPA 260/CAL117.
 COM/COL: Manufacturer: P Kaufmann Contract
 Pattern: Laney PVC
 Color: Custom Cadet
 Finish: Pro Tech
 Fire Rating: CAL TB 117-2013 NFPA 260
 Content: 100% Polyester
 Width: 54"
 Repeat: NA
 Double Rubs: 200,000
 Backing: Polyester
 Railroad: No
 Notes: Heavy duty nylon glides

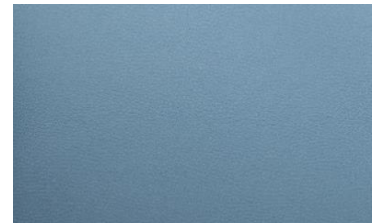

PL-02

Unless Using A Specified Manufacturer, Submit The Following Required Item(s) for Approval Prior to Fabrication:

Finish Sample **Cutting** **Shop Drawing**

Manufacturer to confirm the Product meets Hilton Design and Construction Standards as noted in Section 2515.00

Instructions:

- All quantities to be verified by hotel operator prior to purchasing.
- It is the responsibility of the owner to interpret these specifications for each property.
- All interpretations of the specification MUST be submitted to Hilton Design Review (projecthub.hilton.com) for final approval prior to purchasing or implementation of any material.
- Must be of contract quality and suitable for commercial use.
- COM quantities must be verified by fabricator prior to ordering.
- All materials and methods of construction must comply with all local fire and life safety codes for use in hotels and other public spaces, and Home2 Brand Standards.
- All internal hardware (hinges, screws, bolts, etc.) shall be corrosion proof.



Project Name: Home2 Prototype FF&E Specifications
Scheme: B-Dynamic
Issue Date: March-23
Revisions: May-23 Δ1

Item Number: **(B) PA-101 Supplier B**
Item Name: Dining Chair @ 2 Top Square Table
Area Name: Public Area - Lobby

-
- Wood frames to be certified sustainable sources. All stress joints to be connected by double doweled, screwed and glued corner reinforcement.
 - Manufacturer to provide nylon carpet glides when applicable.
 - All foam, batting, padding, and Dacron wrap shall be fire retardant to meet all applicable codes.
 - Cushions to be adequately vented for displacement of air and to provide increased comfort.
 - Ensure that upholstered goods will fit in elevators and through doors prior to commencing fabrication.
 - Entire frame and upholstery shall be inspected during the manufacturing and again after final assembly. Tailoring shall be neat, trim and performed in a professional manner.
 - Manufacturer to clearly mark each carton with item ID and specification number.
 - Manufacturer to verify all necessary parts, hardware with each item.

Project Name: Home2 Prototype FF&E Specifications
 Scheme: B-Dynamic
 Issue Date: March-23
 Revisions:

Item Number: **(B) PA-102**
 Item Name: Dining Chair at Banquette
 Area Name: Public Area - Lobby

Manufacturer: **ISA**
 Address: 46 Dufflaw Rd.
 Toronto, ON M6A 2W1 Canada
 Phone: 416-782-9100 ext. 229
 Contact: Erik Esteves
 E-mail: erik@havaseat.com
 Web: www.havaseat.com

Description: Upholstered Dining Height Chair with Wood Base
 Model: Fontana Chair 468-LBWG
 Material/Finish: Seat/Back: COM
 Wood Base to match PL-02 Wilsonart High Line 7970K-18 Linearity
 Finish with Aeon 20% sheen level
 Dimensions: 19"W x 22"D x 33"H
 Arm Height: NA
 Seat Height: 19"
 Seat Cushion Style: Attached tight upholstered cushion
 Back Cushion Style: Attached tight upholstered cushion
 Cushion Content: All foam, filling and Dacon wrap shall be fire retardent to meet all applicable codes. Must pass NFPA 260/CAL117.
 COM/COL: Manufacturer: P Kaufmann Contract
 Pattern: Marsciano
 Color: Amethyst
 Finish: Crypton
 Fire Rating: CAL TB 117-2013 NFPA 260
 Content: 100% Polyester
 Width: 54"
 Repeat: 3.5"h x 6.3"v
 Double Rubs: 100,000
 Backing: NA
 Railroad: No
 Notes: Heavy duty nylon glides

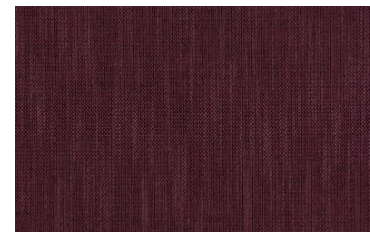

PL-02

Unless Using A Specified Manufacturer, Submit The Following Required Item(s) for Approval Prior to Fabrication:

Finish Sample **Cutting** **Shop Drawing**

Manufacturer to confirm the Product meets Hilton Design and Construction Standards as noted in Section 2515.00

Instructions:

- All quantities to be verified by hotel operator prior to purchasing.
- It is the responsibility of the owner to interpret these specifications for each property.
- All interpretations of the specification MUST be submitted to Hilton Design Review (projecthub.hilton.com) for final approval prior to purchasing or implementation of any material.
- Must be of contract quality and suitable for commercial use.
- COM quantities must be verified by fabricator prior to ordering.



Project Name: Home2 Prototype FF&E Specifications
Scheme: B-Dynamic
Issue Date: March-23

Item Number: **(B) PA-102**
Item Name: Dining Chair at Banquette
Area Name: Public Area - Lobby

Revisions:

- All materials and methods of construction must comply with all local fire and life safety codes for use in hotels and other public spaces, and Home2 Brand Standards.
- All internal hardware (hinges, screws, bolts, etc.) shall be corrosion proof.
- Wood frames to be certified sustainable sources. All stress joints to be connected by double doweled, screwed and glued corner reinforcement.
- Manufacturer to provide nylon carpet glides when applicable.
- All foam, batting, padding, and Dacron wrap shall be fire retardant to meet all applicable codes.
- Cushions to be adequately vented for displacement of air and to provide increased comfort.
- Ensure that upholstered goods will fit in elevators and through doors prior to commencing fabrication.
- Entire frame and upholstery shall be inspected during the manufacturing and again after final assembly. Tailoring shall be neat, trim and performed in a professional manner.
- Manufacturer to clearly mark each carton with item ID and specification number.
- Manufacturer to include all necessary hardware with each item.

Project Name: Home2 Prototype FF&E Specifications
 Scheme: B-Dynamic
 Issue Date: March-23
 Revisions: June-23 Δ2

Item Number: **(B) PA-103**
 Item Name: Lounge Chair at Banquette
 Area Name: Public Area - Lobby

Manufacturer:	Brookline	Edgecombe Furniture	Southfield Furniture
Address:	4015 Cheyenne Dr. Archdale, NC 279263	310 Staton Rd Greenville, NC 27834	2224 Shore Street High Point, NC 27263
Phone:	901-482-6951	252-689-6847	336-434-6220
Contact:	Bill Cotter	Jenna James	Michael Gulledge
E-mail:	Bill@Brooklinefurniture.com	jjames@cottonbeltinc.com	MichaelGulledge@southfieldfurniture.com
Web:	www.brooklinefurniture.com	www.edgecombe.com	www.southfieldfurniture.net

Description: Lounge Chair with Handle and Wood Base
 Material/Finish: Seat/Back: COM
 Wood Base: Solid wood stain to match PL-01 Wilsonart 5th Ave Elm 7966K-12 Soft Grain Texture 20% sheen level
 Wood Handle: Solid wood stain to match PL-01 Wilsonart 5th Ave. Elm 7966K-12 Soft Grain Texture, 20% sheen level
 Overall Dimensions: 32"W x 32"D x 37"H
 Arm Height: 34"
 Seat Height: 18"
 Seat Cushion Style: Removable upholstered, secured with D-Rings
 Back Cushion Style: Tight fully upholstered
 Cushion Content: All foam, filling and Dacon wrap shall be fire retardant to meet all applicable codes. Must pass NFPA 260/CAL117
 COM/COL: Manufacturer: P Kaufmann Contract
 Pattern: B PAL Mod Harlan
 Color: Custom Multi
 Finish: SSR
 Fire Rating: CAL 117, NFPA 260
 Content: 100% Polyester
 Width: 54"
 Repeat: 6.75"H x 6.75"V
 Double Rubs: 100,000
 Backing: Acrylic
 Railroad: No
 Notes: Heavy duty nylon glides

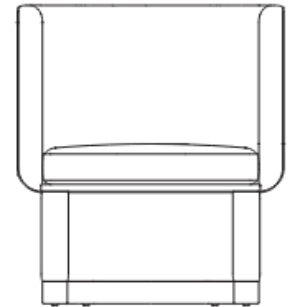

PL-01

Unless Using A Specified Manufacturer, Submit The Following Required Item(s) for Approval Prior to Fabrication:

Finish Sample **Cutting** **Shop Drawing**

Manufacturer to confirm the Product meets Hilton Design and Construction Standards as noted in Section 2515.00

Instructions:

- All quantities to be verified by hotel operator prior to purchasing.
- It is the responsibility of the owner to interpret these specifications for each property.
- All interpretations of the specification MUST be submitted to Hilton Design Review (projecthub.hilton.com) for final approval prior to purchasing or implementation of any material.
- Must be of contract quality and suitable for commercial use.
- COM quantities must be verified by fabricator prior to ordering.



Project Name: Home2 Prototype FF&E Specifications
Scheme: B-Dynamic
Issue Date: March-23
Revisions: June-23 Δ2

Item Number: **(B) PA-103**
Item Name: Lounge Chair at Banquette
Area Name: Public Area - Lobby

-
- All materials and methods of construction must comply with all local fire and life safety codes for use in hotels and other public spaces, and Home2 Brand Standards.
 - All internal hardware (hinges, screws, bolts, etc.) shall be corrosion proof.
 - Wood frames to be certified sustainable sources. All stress joints to be connected by double doweled, screwed and glued corner reinforcement.
 - Manufacturer to provide nylon carpet glides when applicable.
 - All foam, batting, padding, and Dacron wrap shall be fire retardant to meet all applicable codes.
 - Cushions to be adequately vented for displacement of air and to provide increased comfort.
 - Ensure that upholstered goods will fit in elevators and through doors prior to commencing fabrication.
 - Entire frame and upholstery shall be inspected during the manufacturing and again after final assembly. Tailoring shall be neat, trim and performed in a professional manner.
 - Manufacturer to clearly mark each carton with item ID and specification number.
 - Manufacturer to verify all necessary parts, hardware with each item.

Project Name: Home2 Prototype FF&E Specifications
 Scheme: B-Dynamic
 Issue Date: March-23
 Revisions:

Item Number: **(B) PA-104**
 Item Name: Highback Lounge Chair
 Area Name: Public Area - Lobby

Manufacturer: **Edgecombe Furniture**
 Address: 310 Staton Rd
 Greenville, NC 27834
 Phone: 252-689-6847
 Contact: Jenna James
 E-mail: jjames@cottonbeltinc.com
 Web: www.edgecombe.com

Description: Highback Lounge Chair at 2 Top Round Tables
 Material/Finish: Seat/Back: COM
 Wood Base: Solid wood stain to match PL-01 Wilsonart 5th Ave Elm
 7966K-12 Soft Grain Texture 20% sheen level
 Overall Dimensions: 30 1/2"W x 29 1/2"D x 46"H
 Arm Height: 27"
 Seat Height: 19"
 Seat Depth: 24"
 Seat Cushion Style: Tight fully upholstered
 Back Cushion Style: Tight fully upholstered
 Cushion Content: All foam, filling and Dacon wrap shall be fire retardant to meet all applicable codes. Must pass NFPA 260/CAL117
 COM/COL: Manufacturer: P Kaufmann Contract
 Pattern: Bonus Points
 Color: Geranium
 Finish: Nanoclean Free SSR
 Fire Rating: CAL 117-2013, NFPA 260
 Content: 100% Polyester
 Width: 56"
 Repeat: 7.25"h x 15.38"v
 Double Rubs: 63,000
 Backing: Acrylic
 Railroad: No
 Notes: Heavy duty nylon glides



PL-01

Unless Using A Specified Manufacturer, Submit The Following Required Item(s) for Approval Prior to Fabrication:

Finish Sample **Cutting** **Shop Drawing**

Manufacturer to confirm the Product meets Hilton Design and Construction Standards as noted in Section 2515.00

Instructions:

- All quantities to be verified by hotel operator prior to purchasing.
- It is the responsibility of the owner to interpret these specifications for each property.
- All interpretations of the specification MUST be submitted to Hilton Design Review (projecthub.hilton.com) for final approval prior to purchasing or implementation of any material.
- Must be of contract quality and suitable for commercial use.
- COM quantities must be verified by fabricator prior to ordering.
- All materials and methods of construction must comply with all local fire and life safety codes for use in hotels and other public spaces, and Home2 Brand Standards.



Project Name: Home2 Prototype FF&E Specifications
Scheme: B-Dynamic
Issue Date: March-23

Item Number: **(B) PA-104**
Item Name: Highback Lounge Chair
Area Name: Public Area - Lobby

Revisions:

- All internal hardware (hinges, screws, bolts, etc.) shall be corrosion proof.
- Wood frames to be certified sustainable sources. All stress joints to be connected by double doveled, screwed and glued corner reinforcement.
- Manufacturer to provide nylon carpet glides when applicable.
- All foam, batting, padding, and Dacron wrap shall be fire retardant to meet all applicable codes.
- Cushions to be adequately vented for displacement of air and to provide increased comfort.
- Ensure that upholstered goods will fit in elevators and through doors prior to commencing fabrication.
- Entire frame and upholstery shall be inspected during the manufacturing and again after final assembly. Tailoring shall be neat, trim and performed in a professional manner.
- Manufacturer to clearly mark each carton with item ID and specification number.
- Manufacturer to verify all necessary parts, hardware with each item.

Project Name: Home2 Prototype FF&E Specifications
Scheme: B-Dynamic
Issue Date: March-23
Revisions:

Item Number: **(B) PA-105**
Item Name: Focus Booth
Area Name: Public Area - Lobby

Manufacturer: **Edgecombe Furniture**
Address: 310 Staton Rd
Greenville, NC 27834
Phone: 252-689-6847
Contact: Jenna James
E-mail: jjames@cottonbeltinc.com
Web: www.edgecombe.com

Description: Focus Booth at Coffee/Hydration Counter with Quilted Upper Panels.
Refer to PA-201 for Pendant Lighting above Focus Booth.

Material/Finish: Seat/Back: COM
Wood Base: Solid wood stain to match PL-01 Wilsonart 5th Ave Elm
7966K-12 Soft Grain Texture 20% sheen level

Overall Dimensions: 80"W x 37"D x 54"H

Arm Height: 36"

Seat Height: 18"

Seat Depth: 18"

Seat Cushion Style: Tight fully upholstered at all edges

Back Cushion Style: Tight fully upholstered at all edges

Surround Upholstery Style: Tight fully upholstered at all edges, vertical channel tufting at inside back and sides

Cushion Content: All foam, filling and Dacon wrap shall be fire retardant to meet all applicable codes. Must pass NFPA 260/CAL117

Seat COM/COL: Manufacturer: Fil-Doux
Pattern: Sedona
Color: Leisure SKU 102384
Finish: Pro-Tech
Fire Rating: CAL 117-2013, NFPA 260 Class 1
Content: 100% Otratex
Width: 54"
Repeat: NA
Double Rubs: 200,000 +
Backing: 100% Recycled polyester knit
Railroad: No

Seat Back COM: Manufacturer: Fil-Doux
Pattern: Josef
Color: Midnight SKU110475
Finish: Pro-Tech
Fire Rating: CAL 117-2013 NFPA 260
Content: 80% Polyester, 20% Cotton (Experience Blend)
Width: 54"
Repeat: 13.5"H x 13.5"V
Double Rubs:
Backing: No
Railroad: No

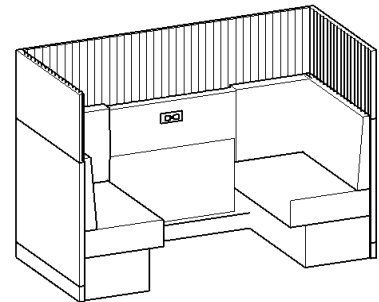

Seat

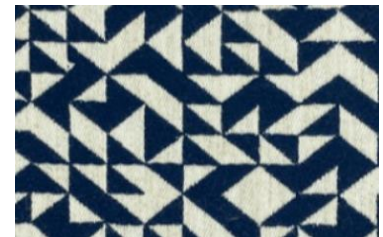

Seat Back



Surround

Project Name: Home2 Prototype FF&E Specifications

Item Number: **(B) PA-105**

Scheme: B-Dynamic

Item Name: Focus Booth

Issue Date: March-23

Area Name: Public Area - Lobby

Revisions:

Surround: Manufacturer: Fil-Doux
Pattern: Chalet
Color: Marine
Finish: Pro-Tech
Fire Rating: CAL 117-2013 NFPA 260 Class 1, IMO Inherent
Content: 100% Otratex
Width: 54"
Repeat: NA
Double Rubs: 200,000 +
Backing: 100% Recycled polyester knit
Railroad: No



PL-01

Notes: Fully Upholstered panels at surround to be finished at all exposed edges. Unit to be shipped as knock down.
Data/Electrical: (1) Mini/multimedia hub (black finish) mounted in back panel (refer to attached drawings) with (2) standard outlets and (2) USB ports. Provide upholstered access panel for access to electrical outlet in back panel.

Unless Using A Specified Manufacturer, Submit The Following Required Item(s) for Approval Prior to Fabrication:

Finish Sample **Cutting** **Shop Drawing**

Manufacturer to confirm the Product meets Hilton Design and Construction Standards as noted in Section 2515.00

Instructions:

- All quantities to be verified by hotel operator prior to purchasing.
- It is the responsibility of the owner to interpret these specifications for each property.
- All interpretations of the specification MUST be submitted to Hilton Design Review (projecthub.hilton.com) for final approval prior to purchasing or implementation of any material.
- Must be of contract quality and suitable for commercial use.
- COM quantities must be verified by fabricator prior to ordering.
- All materials and methods of construction must comply with all local fire and life safety codes for use in hotels and other public spaces, and Home2 Brand Standards.
- All internal hardware (hinges, screws, bolts, etc.) shall be corrosion proof.
- Wood frames to be certified sustainable sources. All stress joints to be connected by double doweled, screwed and glued corner reinforcement.
- Manufacturer to provide nylon carpet glides when applicable.
- All foam, batting, padding, and Dacron wrap shall be fire retardant to meet all applicable codes.
- Cushions to be adequately vented for displacement of air and to provide increased comfort.
- Ensure that upholstered goods will fit in elevators and through doors prior to commencing fabrication.
- Entire frame and upholstery shall be inspected during the manufacturing and again after final assembly. Tailoring shall be neat, trim and performed in a professional manner.
- Manufacturer to clearly mark each carton with item ID and specification number.
- Manufacturer to verify all necessary parts, hardware with each item.

Project Name: Home2 Prototype FF&E Specifications
 Scheme: B-Dynamic
 Issue Date: March-23
 Revisions:

Item Number: **(B) PA-106 Supplier A**
 Item Name: Dining Chair @ 4 Top Tables
 Area Name: Public Area - Lobby

Manufacturer: **ISA**
 Address: 46 Dufflaw Rd.
 Toronto, ON M6A 2W1 Canada

Phone: 416-782-9100 ext. 229
 Contact: Erik Esteves
 E-mail: erik@havaseat.com
 Web: www.havaseat.com

Description: Wood Dining Chair, Upholstered Seat and Back
 Model Name: Baza Chair 880-TWLG Custom Base
 Material/Finish: Seat/Back: COM
 Wood Base: Solid wood stain to match PL-01 Wilsonart 5th Ave Elm
 7966K-12 Soft Grain Texture 20% sheen level
 Metal stretcher finish to match TIGER Drylac Satin Jet Black 38/80020
 in matte finish

Overall Dimensions: 21"W x 25"D x 33"H

Arm Height: NA

Seat Height: ISA: 19.5"

Seat Cushion Style: Attached tight upholstered cushion

Back Cushion Style: Attached tight upholstered cushion

Cushion Content: All foam, filling and Dacon wrap shall be fire retardant to meet all applicable codes. Must pass NFPA 260/CAL117

COM/COL: Manufacturer: KB Contract
 Pattern: Weaver
 Color: Matador
 Finish: Resilience TX
 Fire Rating: CAL TB 117-2013 NFPA 260 UFAC Class 1
 Content: 100% Polyester
 Width: 54"
 Repeat: NA
 Double Rubs: 100,000+
 Backing: SBR
 Railroad: No

Notes: Nylon Glide



Metal Finish

PL-01

Unless Using A Specified Manufacturer, Submit The Following Required Item(s) for Approval Prior to Fabrication:

Finish Sample **Cutting** **Shop Drawing**

Manufacturer to confirm the Product meets Hilton Design and Construction Standards as noted in Section 2515.00

Instructions:

- All quantities to be verified by hotel operator prior to purchasing.
- It is the responsibility of the owner to interpret these specifications for each property.
- All interpretations of the specification MUST be submitted to Hilton Design Review (projecthub.hilton.com) for final approval prior to purchasing or implementation of any material.
- Must be of contract quality and suitable for commercial use.
- COM quantities must be verified by fabricator prior to ordering.



Project Name: Home2 Prototype FF&E Specifications
Scheme: B-Dynamic
Issue Date: March-23

Item Number: **(B) PA-106 Supplier A**
Item Name: Dining Chair @ 4 Top Tables
Area Name: Public Area - Lobby

Revisions:

- All materials and methods of construction must comply with all local fire and life safety codes for use in hotels and other public spaces, and Home2 Brand Standards.
- All internal hardware (hinges, screws, bolts, etc.) shall be corrosion proof.
- Wood frames to be certified sustainable sources. All stress joints to be connected by double doweled, screwed and glued corner reinforcement.
- Manufacturer to provide nylon carpet glides when applicable.
- All foam, batting, padding, and Dacron wrap shall be fire retardant to meet all applicable codes.
- Cushions to be adequately vented for displacement of air and to provide increased comfort.
- Ensure that upholstered goods will fit in elevators and through doors prior to commencing fabrication.
- Entire frame and upholstery shall be inspected during the manufacturing and again after final assembly. Tailoring shall be neat, trim and performed in a professional manner.
- Manufacturer to clearly mark each carton with item ID and specification number.
- Manufacturer to verify all necessary parts, hardware with each item.



Project Name: Home2 Prototype FF&E Specifications
 Scheme: B-Dynamic
 Issue Date: March-23
 Revisions:

Item Number: **(B) PA-106 Supplier B**
 Item Name: Dining Chair @ 4 Top Tables
 Area Name: Public Area - Lobby

Manufacturer: **Sandler**
 Address: 1201 Peachtree St NE Suite 1625
 Atlanta, GA 30361

Phone: 904-962-1137
 Contact: Kati Schoene
 E-mail: kati@sandlerseating.com
 Web: www.sandlerseating.com

Description: Wood Dining Chair, Upholstered Seat and Back
 Model Name: Yarda 1.1
 Material/Finish: Seat/Back: COM
 Wood Base: Solid wood stain to match PL-01 Wilsonart 5th Ave Elm
 7966K-12 Soft Grain Texture 20% sheen level
 Overall Dimensions: 23.2"W x 24.4"D x 31.7"H
 Arm Height: NA
 Seat Height: Sandler: 19.1"
 Seat Cushion Style: Attached tight upholstered cushion
 Back Cushion Style: Attached tight upholstered cushion
 Cushion Content: All foam, filling and Dacon wrap shall be fire retardant to meet all applicable codes. Must pass NFPA 260/CAL117
 COM/COL: Manufacturer: KB Contract
 Pattern: Weaver
 Color: Matador
 Finish: Resilience TX
 Fire Rating: CAL TB 117-2013 NFPA 260 UFAC Class 1
 Content: 100% Polyester
 Width: 54"
 Repeat: NA
 Double Rubs: 100,000+
 Backing: SBR
 Railroad: No
 Notes: Nylon Glide



PL-01

Unless Using A Specified Manufacturer, Submit The Following Required Item(s) for Approval Prior to Fabrication:

Finish Sample **Cutting** **Shop Drawing**

Manufacturer to confirm the Product meets Hilton Design and Construction Standards as noted in Section 2515.00

Instructions:

- All quantities to be verified by hotel operator prior to purchasing.
- It is the responsibility of the owner to interpret these specifications for each property.
- All interpretations of the specification MUST be submitted to Hilton Design Review (projecthub.hilton.com) for final approval prior to purchasing or implementation of any material.
- Must be of contract quality and suitable for commercial use.
- COM quantities must be verified by fabricator prior to ordering.
- All materials and methods of construction must comply with all local fire and life safety codes for use in hotels and other public spaces, and Home2 Brand Standards.
- All internal hardware (hinges, screws, bolts, etc.) shall be corrosion proof.



Project Name: Home2 Prototype FF&E Specifications
Scheme: B-Dynamic
Issue Date: March-23

Item Number: **(B) PA-106 Supplier B**
Item Name: Dining Chair @ 4 Top Tables
Area Name: Public Area - Lobby

Revisions:

- Wood frames to be certified sustainable sources. All stress joints to be connected by double doweled, screwed and glued corner reinforcement.
- Manufacturer to provide nylon carpet glides when applicable.
- All foam, batting, padding, and Dacron wrap shall be fire retardant to meet all applicable codes.
- Cushions to be adequately vented for displacement of air and to provide increased comfort.
- Ensure that upholstered goods will fit in elevators and through doors prior to commencing fabrication.
- Entire frame and upholstery shall be inspected during the manufacturing and again after final assembly. Tailoring shall be neat, trim and performed in a professional manner.
- Manufacturer to clearly mark each carton with item ID and specification number.
- Manufacturer to verify all necessary parts, hardware with each item.

Project Name: Home2 FF&E Specifications
 Scheme: B-Dynamic
 Issue Date: March-23
 Revisions:

Item Number: **(B) PA-107**
 Item Name: Counter Stool at Perch Table
 Area Name: Public Area - Lobby

Manufacturer: **ISA**
 Address: 46 Dufflaw Rd.
 Toronto, ON M6A 2W1 Canada
 Phone: 416-782-9100 ext. 229
 Contact: Erik Esteves
 E-mail: erik@havaseat.com
 Web: www.havaseat.com

Description: Wood Counter Stool with Upholstered Seat and Back
 Model Name/No. Custom Catalana Counter Stool UAP/UBP
 Material/Finish: Seat/Back: COM
 Wood Base: Solid wood stain to match PL-02 Wilsonart High Line
 7970K-18 Linearity Finish with Aeon 20% sheen level
 Overall Dimensions: 19"W x 20"D x 37"H
 Arm Height: NA
 Seat Height: 24"
 Seat Cushion Style: Attached tight upholstered cushion
 Back Cushion Style: Attached tight upholstered cushion
 Cushion Content: All foam, filling and Dacon wrap shall be fire retardant to meet all applicable codes. Must pass NFPA 260/CAL117
 COM/COL: Manufacturer: Fil-Doux
 Pattern: Tome
 Color: Tangerine SKU 110620
 Finish: Pro-Tech
 Fire Rating: CAL 117-2013 NFPA 260 Class 1
 Content: 85% Polyester, 20% cotton
 Width: 54"
 Repeat: NA
 Double Rubs: 60,000 +
 Backing: Acrylic
 Railroad: No
 Notes: Heavy duty nylon glides



Metal Finish

PL-02

Unless Using A Specified Manufacturer, Submit The Following Required Item(s) for Approval Prior to Fabrication:

Finish Sample **Cutting** **Shop Drawing**

Manufacturer to confirm the Product meets Hilton Design and Construction Standards as noted in Section 2515.00

Instructions:

- All quantities to be verified by hotel operator prior to purchasing.
- It is the responsibility of the owner to interpret these specifications for each property.
- All interpretations of the specification MUST be submitted to Hilton Design Review (projecthub.hilton.com) for final approval prior to purchasing or implementation of any material.
- Must be of contract quality and suitable for commercial use.
- COM quantities must be verified by fabricator prior to ordering.



Project Name: Home2 FF&E Specifications
Scheme: B-Dynamic
Issue Date: March-23

Item Number: **(B) PA-107**
Item Name: Counter Stool at Perch Table
Area Name: Public Area - Lobby

Revisions:

- All materials and methods of construction must comply with all local fire and life safety codes for use in hotels and other public spaces, and Home2 Brand Standards.
- All internal hardware (hinges, screws, bolts, etc.) shall be corrosion proof.
- Wood frames to be certified sustainable sources. All stress joints to be connected by double doweled, screwed and glued corner reinforcement.
- Manufacturer to provide nylon carpet glides when applicable.
- All foam, batting, padding, and Dacron wrap shall be fire retardant to meet all applicable codes.
- Cushions to be adequately vented for displacement of air and to provide increased comfort.
- Ensure that upholstered goods will fit in elevators and through doors prior to commencing fabrication.
- Entire frame and upholstery shall be inspected during the manufacturing and again after final assembly. Tailoring shall be neat, trim and performed in a professional manner.
- Manufacturer to clearly mark each carton with item ID and specification number.
- Manufacturer to verify all necessary parts, hardware with each item.

Project Name: Home2 Prototype FF&E Specifications Item Number: **(B) PA-108**
 Scheme: B-Dynamic Item Name: Single Sofa @ TV Lounge
 Issue Date: March-23 Area Name: Public Area - TV Lounge
 Revisions: May-23 Δ1

Manufacturer:	Brookline	Edgecombe Furniture	Southfield Furniture	Transformations
Address:	4015 Cheyenne Dr. Archdale, NC 279263	310 Staton Rd Greenville, NC 27834	2224 Shore Street High Point, NC 27263	310 Racquet Drive Fort Wayne, IN 46825
Phone:	901-482-6951	252-689-6847	336-434-6220	260-402-5999
Contact:	Bill Cotter	Jenna James	Michael Gulledege	Stu Reynolds
E-mail:	Bill@Brooklinefurniture.com	jjames@cottonbeltinc.com	MichaelGulledege@southfieldfurniture.net	stu@trfurniture.com
Web:	www.brooklinefurniture.com	www.edgecombe.com	www.southfieldfurniture.net	www.transformationshospitality.com

Description: Large Modular Sofa at TV Lounge
 Material/Finish: Seat/Back: COM Wood
 Base: Solid wood stain to match PL-01 Wilsonart 5th Ave Elm 7966K-12 Soft Grain Texture 20% sheen level
 Overall Dimensions: 60"W x 34"D x 30"H
 Leg Height: 2"
 Arm Height: NA
 Seat Height: 17"
 Seat Depth: 24"
 Seat Cushion Style: Tight fully upholstered
 Back Cushion Style: Tight fully upholstered
 Cushion Content: All foam, filling and Dacon wrap shall be fire retardant to meet all applicable codes. Must pass NFPA 260/CAL117
 COM/COL: Manufacturer: Fil-Doux
 Pattern: Fjord
 Color: Pacific SKU 110625
 Finish: Pro-Tech
 Fire Rating: CAL 117-2013 NFPA 260 Class 1
 Content: 80% Polyester, 20% Acrylic (Experience Blend)
 Width: 54"
 Repeat: NA
 Double Rubs: 60,000+
 Backing: Acrylic
 Railroad: No
 Notes: No Welting or Cording
 Provide ganging hardware
 Heavy duty nylon glides
 Data/Electrical: (1) Mini/multimedia hub (black finish) mounted in laminate base with (2) standard outlets and (2) USB ports. No Welting or Cording



PL-01

Unless Using A Specified Manufacturer, Submit The Following Required Item(s) for Approval Prior to Fabrication:

Finish Sample **Cutting** **Shop Drawing**

Manufacturer to confirm the Product meets Hilton Design and Construction Standards as noted in Section 2515.00

Instructions:

- All quantities to be verified by hotel operator prior to purchasing.
- It is the responsibility of the owner to interpret these specifications for each property.



Project Name: Home2 Prototype FF&E Specifications
Scheme: B-Dynamic
Issue Date: March-23
Revisions: May-23 Δ1

Item Number: **(B) PA-108**
Item Name: Single Sofa @ TV Lounge
Area Name: Public Area - TV Lounge

-
- All interpretations of the specification MUST be submitted to Hilton Design Review (projecthub.hilton.com) for final approval prior to purchasing or implementation of any material.
 - Must be of contract quality and suitable for commercial use.
 - COM quantities must be verified by fabricator prior to ordering.
 - All materials and methods of construction must comply with all local fire and life safety codes for use in hotels and other public spaces, and Home2 Brand Standards.
 - All internal hardware (hinges, screws, bolts, etc.) shall be corrosion proof.
 - Wood frames to be certified sustainable sources. All stress joints to be connected by double doweled, screwed and glued corner reinforcement.
 - Manufacturer to provide nylon carpet glides when applicable.
 - All foam, batting, padding, and Dacron wrap shall be fire retardant to meet all applicable codes.
 - Cushions to be adequately vented for displacement of air and to provide increased comfort.
 - Ensure that upholstered goods will fit in elevators and through doors prior to commencing fabrication.
 - Entire frame and upholstery shall be inspected during the manufacturing and again after final assembly. Tailoring shall be neat, trim and performed in a professional manner.
 - Manufacturer to clearly mark each carton with item ID and specification number.
 - Manufacturer to verify all necessary parts, hardware with each item.



Project Name: Home2 Prototype FF&E Specifications
Scheme: B-Dynamic
Issue Date: March-23

Item Number: **(B) PA-109**
Item Name: Counter Stool @ Laundry Room
Area Name: Public Area - Laundry Room

Revisions:

Manufacturer: **Emeco Industries**
Address: 805 Elm Avenue
Hanover, PA 17331
Phone: 562-533-0031
Contact: Chris Correll
E-mail: chris@emeco.net
Web: www.emeco.net

Description: Molded Outdoor Counter Height Stool with Metal Foot Rail
Model Name/No: Broom Counter Stool
Material/Finish: Broom 24 Dark Grey
Overall Dimension: 16 1/2"W x 18 "D x 38"H
Arm Height: NA
Seat Height: 24"H
Seat Cushion Style: NA
Back Cushion Style: NA
Cushion Content: NA
COM/COL: NA



Notes:

Unless Using A Specified Manufacturer, Submit The Following Required Item(s) for Approval Prior to Fabrication:

Finish Sample **Shop Drawing**

Manufacturer to confirm the Product meets Hilton Design and Construction Standards as noted in Section 2515.00

Instructions:

- All quantities to be verified by hotel operator prior to purchasing.
- It is the responsibility of the owner to interpret these specifications for each property.
- All interpretations of the specification MUST be submitted to Hilton Design Review (projecthub.hilton.com) for final approval prior to purchasing or implementation of any material.
- Must be of contract quality and suitable for commercial use.
- All materials and methods of construction must comply with all local fire and life safety codes for use in hotels and other public spaces, and Brand Standards.
- All internal hardware (hinges, screws, bolts, etc.) shall be corrosion proof.
- Wood frames to be certified sustainable sources. All stress joints to be connected by double doweled, screwed and glued corner reinforcement.
- Manufacturer to provide nylon carpet glides when applicable.
- Ensure that upholstered goods will fit in elevators and through doors prior to commencing fabrication.
- Manufacturer to clearly mark each carton with item ID and specification number.
- Manufacturer to include all necessary hardware with each item.

Project Name: Home2 Prototype FF&E Specifications
 Scheme: B-Dynamic
 Issue Date: March-23
 Revisions:

Item Number: **(B) PA-110**
 Item Name: Employee Breakroom Chair
 Area Name: Breakroom

Manufacturer: **ISA**
 Address: 46 Dufflaw Rd.
 Toronto, ON M6A 2W1 Canada
 Phone: 416-782-9100 ext. 229
 Contact: Erik Esteves
 E-mail: erik@havaseat.com
 Web: www.havaseat.com

Description: Molded Polypropylene Shell Chair with Metal Legs
 Model Name: 306-SMLG Zodiac Stack
 Material/Finish: Polypropylene: Red
 Legs: P77 Polished Chrome
 Overall Dimensions: 18"W 21"D 31 1/2"H
 Arm Height: NA
 Seat Height: 18"
 Seat Cushion Style: NA
 Back Cushion Style: NA
 Cushion Content: NA
 COM/COL: NA
 Notes: Glides: Suitable for ERT



Unless Using A Specified Manufacturer, Submit The Following Required Item(s) for Approval Prior to Fabrication:

Finish Sample **Shop Drawing**

Manufacturer to confirm the Product meets Hilton Design and Construction Standards as noted in Section 2515.00

Instructions:

- All quantities to be verified by hotel operator prior to purchasing.
- It is the responsibility of the owner to interpret these specifications for each property.
- All interpretations of the specification MUST be submitted to Hilton Design Review (projecthub.hilton.com) for final approval prior to purchasing or implementation of any material.
- Must be of contract quality and suitable for commercial use.
- COM quantities must be verified by fabricator prior to ordering.
- All materials and methods of construction must comply with all local fire and life safety codes for use in hotels and other public spaces, and Home2 Brand Standards.
- All internal hardware (hinges, screws, bolts, etc.) shall be corrosion proof.
- Wood frames to be certified sustainable sources. All stress joints to be connected by double doweled, screwed and glued corner reinforcement.
- Manufacturer to provide nylon carpet glides when applicable.
- All foam, batting, padding, and Dacron wrap shall be fire retardant to meet all applicable codes.
- Cushions to be adequately vented for displacement of air and to provide increased comfort.
- Ensure that upholstered goods will fit in elevators and through doors prior to commencing fabrication.
- Entire frame and upholstery shall be inspected during the manufacturing and again after final assembly. Tailoring shall be neat, trim and performed in a professional manner.
- Manufacturer to clearly mark each carton with item ID and specification number.
- Manufacturer to verify all necessary parts, hardware with each item.

Project Name: Home2 Prototype FF&E Specifications
 Scheme: B-Dynamic
 Issue Date: March-23
 Revisions:

Item Number: **(B) PA-111**
 Item Name: Meeting Room Stack Chair
 Area Name: Public Area - Meeting Room

Manufacturer: **MTS Seating**
 Address: 7100 Industrial Drive
 Temperance, MI 481182
 Phone: 734-847-3875
 Contact: Lisa McAfee
 E-mail: lisamcafee@mtsseating.com
 Web: www.mtsseating.com

Description: Stacking Chair @ Board Room
 Model: Omega II Series Banquet Stacking Chair Model Item # C578.
 Including Silhouette style back and stack bars
 Material/Finish: Seat/Back: Graded-in fabric
 Pattern: Flux, color FLX601 Carmine
 Metal Frame: Solid Satin Black S-18
 Overall Dimensions: 18" W x 22.5" D x 36.5" H
 Arm Height: NA
 Seat Height: 18.75"
 Seat Depth: NA
 Seat Cushion Style: 2" Waterfall, attached w/ COMFORTbliss® pad
 Back Cushion Style: Attached
 Cushion Content: NA
 COM/COL: NA
 Notes: Glides: Nylon swivel floor glides, included
 Graded-In Fabric: Pattern: Flux, color FLX601 Carmine



Frame Finish

Unless Using A Specified Manufacturer, Submit The Following Required Item(s) for Approval Prior to Fabrication:

Finish Sample **Cutting** **Shop Drawing**

Manufacturer to confirm the Product meets Hilton Design and Construction Standards as noted in Section 2515.00

Instructions:

Instructions:

- All quantities to be verified by hotel operator prior to purchasing.
- It is the responsibility of the owner to interpret these specifications for each property.
- All interpretations of the specification MUST be submitted to Hilton Design Review (projecthub.hilton.com) for final approval prior to purchasing or implementation of any material.
- Must be of contract quality and suitable for commercial use.



Project Name: Home2 Prototype FF&E Specifications
Scheme: B-Dynamic
Issue Date: March-23

Item Number: **(B) PA-111**
Item Name: Meeting Room Stack Chair
Area Name: Public Area - Meeting Room

Revisions:

- COM quantities must be verified by fabricator prior to ordering.
- All materials and methods of construction must comply with all local fire and life safety codes for use in hotels and other public spaces, and Home2 Brand Standards.
- All internal hardware (hinges, screws, bolts, etc.) shall be corrosion proof.
- Wood frames to be certified sustainable sources. All stress joints to be connected by double doweled, screwed and glued corner reinforcement.
- Manufacturer to provide nylon carpet glides when applicable.
- All foam, batting, padding, and Dacron wrap shall be fire retardant to meet all applicable codes.
- Cushions to be adequately vented for displacement of air and to provide increased comfort.
- Ensure that upholstered goods will fit in elevators and through doors prior to commencing fabrication.
- Entire frame and upholstery shall be inspected during the manufacturing and again after final assembly. Tailoring shall be neat, trim and performed in a professional manner.
- Manufacturer to clearly mark each carton with item ID and specification number.
- Manufacturer to verify all necessary parts, hardware with each item.

Project Name: Home2 FF&E Specs
 Scheme: (B) Dynamic
 Issue Date: March-23
 Revisions: May-23 Δ1

Item Number: **(B) PA-112**
 Item Name: Task Chair
 Area Name: Public Area - Meeting Room

Manufacturer: **Humanscale Corporation**
 Address: 535 Anton Blvd, Suite 160 Costa
 Mesa, CA 92626
 Phone: 714.290.0847
 Contact: Peter Hart
 E-mail: phart@humanscale.com
 Web: www.humanscale.com

Description: Task Chair with Mesh Back and Upholstered Seat
 Model Name: Diffrient World®
 Material/Finish: Back: Mesh Pinstripe - Crimson
 Seat: Lotus - Lucky Red Finish: Black
 Dimensions: Overall: 26" W x 36.5" D x 41.5" H
 Arm Height: 23.8"-32" H (adjustable)
 Seat Height: 16"-21" H (adjustable)
 Seat Depth: 16.5"-20" D
 Seat Cushion Style: Fabric w/ frameless front edge; upholstered polyurethane foam seat cushion
 Back Cushion Style: Non-stretch mesh w/ frameless front edge; upholstered polyurethane foam seat cushion
 Cushion Content: Form sensing non-stretch mesh upholstered over polyurethane foam seat cushion
 Seat Back: Form sensing non-stretch tri-panel mesh
 COM/COL: NA
 Notes: Five star base with hydraulic gas lift and heavy duty black nylon casters.

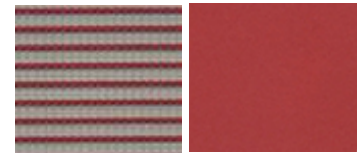

Back Seat

REQUIRED VENDOR, REQUIRED DESIGN

Instructions:

- All quantities to be verified by hotel operator prior to purchasing.
- It is the responsibility of the owner to interpret these specifications for each property.
- All interpretations of the specification MUST be submitted to Hilton Design Review (projecthub.hilton.com) for final approval prior to purchasing or implementation of any material.
- Must be of contract quality and suitable for commercial use.
- COM quantities must be verified by fabricator prior to ordering.
- All materials and methods of construction must comply with all local fire and life safety codes for use in hotels and other public spaces, and Brand Standards.
- All internal hardware (hinges, screws, bolts, etc.) shall be corrosion proof.
- Wood frames to be certified sustainable sources. All stress joints to be connected by double doweled, screwed and glued corner reinforcement.
- Manufacturer to provide nylon carpet glides when applicable.
- All foam, batting, padding, and Dacron wrap shall be fire retardant to meet all applicable codes.



Project Name: Home2 FF&E Specs
Scheme: (B) Dynamic
Issue Date: March-23
Revisions: May-23 Δ1

Item Number: **(B) PA-112**
Item Name: Task Chair
Area Name: Public Area - Meeting Room

-
- Cushions to be adequately vented for displacement of air and to provide increased comfort.
 - Ensure that upholstered goods will fit in elevators and through doors prior to commencing fabrication.
 - Entire frame and upholstery shall be inspected during the manufacturing and again after final assembly. Tailoring shall be neat, trim and performed in a professional manner.
 - Manufacturer to clearly mark each carton with item ID and specification number.
 - Manufacturer to include all necessary hardware with each item.



Project Name: Home2 Prototype FF&E Specifications Item Number: **(B) PA-113**
 Scheme: B-Dynamic Item Name: Large Sofa @ TV Lounge
 Issue Date: May-23 Area Name: Public Area - TV Lounge

Revisions:

Manufacturer:	Brookline	Edgecombe Furniture	Southfield Furniture	Transformations
Address:	4015 Cheyenne Dr. Archdale, NC 279263	310 Staton Rd Greenville, NC 27834	2224 Shore Street High Point, NC 27263	310 Racquet Drive Fort Wayne, IN 46825
Phone:	901-482-6951	252-689-6847	336-434-6220	260-402-5999
Contact:	Bill Cotter	Jenna James	Michael Gulledege	Stu Reynolds
E-mail:	Bill@Brooklinefurniture.com	jjames@cottonbeltinc.com	MichaelGulledege@southfieldfurniture.net	stu@trfurniture.com
Web:	www.brooklinefurniture.com	www.edgecombe.com	www.southfieldfurniture.net	www.transformationshospitality.com

Description: Large Modular Sofa at TV Lounge

Material/Finish: Seat/Back: COM Wood
 Base: Solid wood stain to match PL-01 Wilsonart 5th Ave Elm 7966K-12 Soft
 Grain Texture 20% sheen level

Overall Dimensions: 120"W x 34"D x 30"H

Leg Height: 2"

Arm Height: NA

Seat Height: 17"

Seat Depth: 24"

Seat Cushion Style: Tight fully upholstered

Back Cushion Style: Tight fully upholstered

Cushion Content: All foam, filling and Dacon wrap shall be fire retardant to meet all applicable codes. Must pass NFPA 260/CAL117

COM/COL: Manufacturer: Fil-Doux
 Pattern: Fjord
 Color: Pacific SKU 110625
 Finish: Pro-Tech
 Fire Rating: CAL 117-2013 NFPA 260 Class 1
 Content: 80% Polyester, 20% Acrylic (Experience Blend)
 Width: 54"
 Repeat: NA
 Double Rubs: 60,000+
 Backing: Acrylic
 Railroad: No

Notes: No Welting or Cording
 Provide ganging hardware
 Heavy duty nylon glides
 Data/Electrical: (2) Mini/multimedia hub (black finish) mounted in laminate base with (2) standard outlets and (2) USB ports. No Welting or Cording



PL-01

Unless Using A Specified Manufacturer, Submit The Following Required Item(s) for Approval Prior to Fabrication:

Finish Sample **Cutting** **Shop Drawing**

Manufacturer to confirm the Product meets Hilton Design and Construction Standards as noted in Section 2515.00

Instructions:

- All quantities to be verified by hotel operator prior to purchasing.
- It is the responsibility of the owner to interpret these specifications for each property.



Project Name: Home2 Prototype FF&E Specifications
Scheme: B-Dynamic
Issue Date: May-23

Item Number: **(B) PA-113**
Item Name: Large Sofa @ TV Lounge
Area Name: Public Area - TV Lounge

Revisions:

-
- All interpretations of the specification MUST be submitted to Hilton Design Review (projecthub.hilton.com) for final approval prior to purchasing or implementation of any material.
 - Must be of contract quality and suitable for commercial use.
 - COM quantities must be verified by fabricator prior to ordering.
 - All materials and methods of construction must comply with all local fire and life safety codes for use in hotels and other public spaces, and Home2 Brand Standards.
 - All internal hardware (hinges, screws, bolts, etc.) shall be corrosion proof.
 - Wood frames to be certified sustainable sources. All stress joints to be connected by double doveled, screwed and glued corner reinforcement.
 - Manufacturer to provide nylon carpet glides when applicable.
 - All foam, batting, padding, and Dacron wrap shall be fire retardant to meet all applicable codes.
 - Cushions to be adequately vented for displacement of air and to provide increased comfort.
 - Ensure that upholstered goods will fit in elevators and through doors prior to commencing fabrication.
 - Entire frame and upholstery shall be inspected during the manufacturing and again after final assembly. Tailoring shall be neat, trim and performed in a professional manner.
 - Manufacturer to clearly mark each carton with item ID and specification number.
 - Manufacturer to verify all necessary parts, hardware with each item.

Project Name: Home2 Prototype FF&E Specifications Item Number: **(B) PA-201**
 Scheme: B-Dynamic Item Name: Pendant Lighting @ Focus Booth
 Issue Date: March-23 Area Name: Public Area - Lobby
 Revisions: May-23 Δ1

Manufacturer:	Arkansas Lighting	Illumination Lighting	Trinity Lighting
Address:	1701 South 28th Street Van Buren, AR 72956	2300 Victoria Ave Lachine, Quebec H8S 1Z3	2902 Quality Way Jonesboro, AR 72401
Phone:	479-474-0876	514-634-7200 ext 225	870-972-1177
Contact:	Maria Gunter	Annette Serrao	Sonja Hutchison
E-mail:	mgunter@arkansaslighting.com	annette@illuminationlighting.com	shutchison@trinitylighting.com
Web:	www.arkansaslighting.com	www.illuminationlighting.com	www.trinitylighting.com

Description: Hardwired Pendant at Focus Booth
 Overall Dimensions: 27" Dia. x 16"H x 36"OH, Canopy 8" Dia.
 Finish: Powdercoated stainless steel exterior to match RAL 9011 Graphite
 Black matte finish, interior to match RAL 9010 Pure White
 Switch Type: Hardwired
 Cord Length: 72", adjustable in field
 Cord Color: Black cloth cord cover
 Lamp Type: A15 LED, E26 Medium Socket 3000K
 Lamp Wattage: 11W
 Lamp Quantity: 1
 UL Listing: Fixture must be U.L. listed and so labeled
 Shade/Diff. Style: Bell shape shade, open at bottom
 Shade/Diff. Material: Powdercoated stainless steel
 Shade/Diff. Dims.: 27"Dia. x 14"h
 Suspension Info: Refer to architectural drawings for mounting height and location
 Notes: Manufacturer to provide mounting hardware and accessories

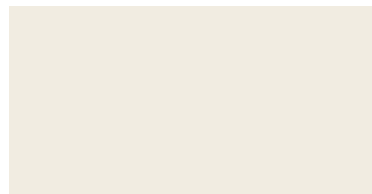
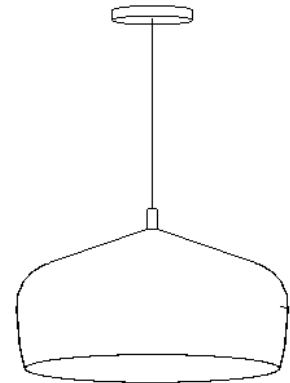

Interior Finish



Exterior Finish

Unless Using A Specified Manufacturer, Submit The Following Required Item(s) for Approval Prior to Fabrication:

Finish Sample **Shop Drawing**

Manufacturer to confirm the Product meets Hilton Design and Construction Standards as noted in Section 2515.00

Instructions:

- All quantities to be verified by hotel operator prior to purchasing.
- It is the responsibility of the owner to interpret these specifications for each property.
- All interpretations of the specification MUST be submitted to Hilton Design Review (projecthub.hilton.com) for final approval prior to purchasing or implementation of any material.
- Must be of contract quality and suitable for commercial use.
- All materials and methods of construction must comply with all local fire and life safety codes and Brand Standards.
- Fixture must be U.L. Listed and so labeled. Manufacturer is responsible for submitting all technical specifications for fire safety, UL standards, and any other specifications that are required to comply with local and state fire codes.



Project Name: Home2 Prototype FF&E Specifications
Scheme: B-Dynamic
Issue Date: March-23
Revisions: May-23 Δ 1

Item Number: **(B) PA-201**
Item Name: Pendant Lighting @ Focus Booth
Area Name: Public Area - Lobby

-
- Manufacturer/Fabricator to confirm weight of fixture.
 - Manufacturer/Fabricator to verify installation method and hanging points.
 - Show all pieces in scaled shop drawings. Entire fixture shall be inspected during the manufacturing and again after final assembly.
 - Manufacturer to clearly mark each carton with item ID and specification number.



Project Name: Home2 Prototype FF&E Specifications
Scheme: B-Dynamic
Issue Date: March-23
Revisions: May-23 Δ1

Item Number: **(B) PA-202 Supplier A**
Item Name: Bathroom Vanity Light
Area Name: Public Area - Bathroom

Manufacturer: **Arkansas Lighting**
Address: 1701 South 28th Street
Van Buren, AR 72956
Phone: 479-474-0876
Contact: Maria Gunter
E-mail: mgunter@arkansaslighting.com
Web: www.arkansaslighting.com

Description: Bathroom Vanity Light with Square Backplate

Overall Dimensions: Overall width: 24"W; 4"H x 2 1/2"D

Finish: Shade: Frosted white acrylic
Backplate & End Caps: Stainless steel metal powdercoated to match
RAL 9011 matte finish

Switch Type: Hardwired

Cord Length: NA

Cord Color: NA

Lamp Type: 15W LED board 3000K

Lamp Wattage: 15 W

Lamp Quantity: 2

UL Listing: Fixture must be U.L. listed and labeled

Shade/Diff. Style: Cylinder

Shade/Diff. Material: Top: Frosted white matte acrylic and powdercoated stainless steel metal, Bottom: Powdercoated stainless steel metal

Shade/Diff. Dims.: 24"W x 1 3/4"D x 1 3/4"H

Mounting Instructions: Wall mounted, refer to architectural drawings for mounting height

Notes: Manufacturer to provide mounting hardware and accessories

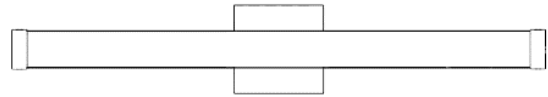

Backplate/End Cap Finish

Unless Using A Specified Manufacturer, Submit The Following Required Item(s) for Approval Prior to Fabrication:

Finish Sample **Shop Drawing**

Manufacturer to confirm the Product meets Hilton Design and Construction Standards as noted in Section 2515.00

Instructions:

- All quantities to be verified by hotel operator prior to purchasing.
- It is the responsibility of the owner to interpret these specifications for each property.
- All interpretations of the specification MUST be submitted to Hilton Design Review (projecthub.hilton.com) for final approval prior to purchasing or implementation of any material.
- Must be of contract quality and suitable for commercial use.
- All materials and methods of construction must comply with all local fire and life safety codes and Brand Standards.
- Fixture must be U.L. Listed and so labeled. Manufacturer is responsible for submitting all technical specifications for fire safety, UL standards, and any other specifications that are required to comply with local and state fire codes.
- Manufacturer/Fabricator to confirm weight of fixture.
- Manufacturer/Fabricator to verify installation method and hanging points.
- Show all pieces in scaled shop drawings. Entire fixture shall be inspected during the manufacturing and again after final assembly.
- Manufacturer to clearly mark each carton with item ID and specification number.



Project Name: Home2 Prototype FF&E Specifications
 Scheme: B-Dynamic
 Issue Date: March-23
 Revisions: May-23 Δ1

Item Number: **(B) PA-202 Supplier B**
 Item Name: Bathroom Vanity Light
 Area Name: Public Area - Bathroom

Manufacturer: **Illumination Lighting**
 Address: 2300 Victoria Ave
 Lachine, Quebec H8S 1Z3
 Phone: 514-634-7200 ext. 225
 Contact: Annette Serrao
 E-mail: annette@illuminationlighting.com
 Web: www.illuminationlighting.com

Description: Bathroom Vanity Light with Square Backplate
 Overall Dimensions: Overall width: 24"W; 4 1/2"H x 2 1/2"D
 Finish: Shade: Frosted white acrylic
 Backplate & End Caps: Stainless steel metal powdercoated to match RAL 9011 matte finish
 Switch Type: Hardwired
 Cord Length: NA
 Cord Color: NA
 Lamp Type: 15W LED board 3000K
 Lamp Wattage: 15 W
 Lamp Quantity: 2
 UL Listing: Fixture must be U.L. listed and labeled
 Shade/Diff. Style: Cylinder
 Shade/Diff. Material: Top: Frosted white matte acrylic and powdercoated stainless steel metal, Bottom: Powdercoated stainless steel metal
 Shade/Diff. Dims.: 24"W x 1 3/4"D x 1 3/4"H
 Mounting Instructions: Wall mounted, refer to architectural drawings for mounting height
 Notes: Manufacturer to provide mounting hardware and accessories



Backplate/End Cap Finish

Unless Using A Specified Manufacturer, Submit The Following Required Item(s) for Approval Prior to Fabrication:
Finish Sample **Shop Drawing**

Manufacturer to confirm the Product meets Hilton Design and Construction Standards as noted in Section 2515.00

Instructions:

- All quantities to be verified by hotel operator prior to purchasing.
- It is the responsibility of the owner to interpret these specifications for each property.
- All interpretations of the specification MUST be submitted to Hilton Design Review (projecthub.hilton.com) for final approval prior to purchasing or implementation of any material.
- Must be of contract quality and suitable for commercial use.
- All materials and methods of construction must comply with all local fire and life safety codes and Brand Standards.
- Fixture must be U.L. Listed and so labeled. Manufacturer is responsible for submitting all technical specifications for fire safety, UL standards, and any other specifications that are required to comply with local and state fire codes.
- Manufacturer/Fabricator to confirm weight of fixture.
- Manufacturer/Fabricator to verify installation method and hanging points.
- Show all pieces in scaled shop drawings. Entire fixture shall be inspected during the manufacturing and again after final assembly.
- Manufacturer to clearly mark each carton with item ID and specification number.



Project Name: Home2 Prototype FF&E Specifications
Scheme: B-Dynamic
Issue Date: March-23
Revisions: May-23 Δ1

Item Number: **(B) PA-202 Supplier C**
Item Name: Bathroom Vanity Light
Area Name: Public Area - Bathroom

Manufacturer: **Trinity Lighting**
Address: 2902 Quality Way
Jonesboro, AR 72401
Phone: 870-972-1177
Contact: Sonja Hutchison
E-mail: shutchison@trinitylighting.com
Web: www.trinitylighting.com

Description: Bathroom Vanity Light with Square Backplate
Overall Dimensions: Overall width: 24"W; 4 1/2"H x 2 3/8"D
Finish: Shade: Frosted white acrylic
Backplate & End Caps: Stainless steel metal powdercoated to match RAL 9011 matte finish
Switch Type: Hardwired
Cord Length: NA
Cord Color: NA
Lamp Type: LED Strip 3000K
Lamp Wattage: 15 W
Lamp Quantity: 2
UL Listing: Fixture must be U.L. listed and labeled
Shade/Diff. Style: Cylinder
Shade/Diff. Material: Top: Frosted white matte acrylic and powdercoated stainless steel metal, Bottom: Powdercoated stainless steel metal
Shade/Diff. Dims.: 24"W x 1 3/4"D x 1 3/4"H
Mounting Instructions: Wall mounted, refer to architectural drawings for mounting height
Notes: Manufacturer to provide mounting hardware and accessories

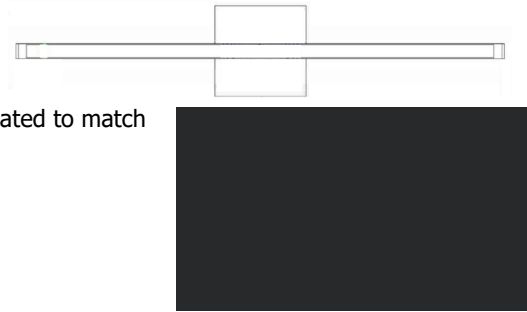

Backplate/End Cap Finish

Unless Using A Specified Manufacturer, Submit The Following Required Item(s) for Approval Prior to Fabrication:
Finish Sample **Shop Drawing**

Manufacturer to confirm the Product meets Hilton Design and Construction Standards as noted in Section 2515.00

Instructions:

- All quantities to be verified by hotel operator prior to purchasing.
- It is the responsibility of the owner to interpret these specifications for each property.
- All interpretations of the specification MUST be submitted to Hilton Design Review (projecthub.hilton.com) for final approval prior to purchasing or implementation of any material.
- Must be of contract quality and suitable for commercial use.
- All materials and methods of construction must comply with all local fire and life safety codes and Brand Standards.
- Fixture must be U.L. Listed and so labeled. Manufacturer is responsible for submitting all technical specifications for fire safety, UL standards, and any other specifications that are required to comply with local and state fire codes.
- Manufacturer/Fabricator to confirm weight of fixture.
- Manufacturer/Fabricator to verify installation method and hanging points.
- Show all pieces in scaled shop drawings. Entire fixture shall be inspected during the manufacturing and again after final assembly.
- Manufacturer to clearly mark each carton with item ID and specification number.

Project Name: Home2 Prototype FF&E Specifications Item Number: **(B) PA-203**
 Scheme: B-Dynamic Item Name: Floor Lamp @ TV Lounge
 Issue Date: March-23 Area Name: Public Area - TV Lounge
 Revisions: May-23 Δ1

Manufacturer:	Arkansas Lighting	Illumination Lighting	Trinity Lighting
Address:	1701 South 28th Street Van Buren, AR 72956	2300 Victoria Ave Lachine, Quebec H8S 1Z3	2902 Quality Way Jonesboro, AR 72401
Phone:	479-474-0876	514-634-7200 ext. 225	870-972-1177
Contact:	Maria Gunter	Annette Serrao	Sonja Hutchison
E-mail:	mgunter@arkansaslighting.com	annette@illuminationlighting.com	shutchison@trinitylighting.com
Web:	www.arkansaslighting.com	www.illuminationlighting.com	www.trinitylighting.com

Description: Floor Lamp at TV Lounge
 Overall Dimensions: 12"W x 17"D x 60"H
 Finish: Base Plate & Stem: To match RAL 9011 Graphite Black in matte finish
 Switch Type: On/Off Accessible mini rocker base switch on stem, 36" above base.
 Finish: Black
 Cord Length: 72"
 Cord Color: Clear/Silver
 Plug Type: 90°/Right angle plug
 Lamp Type: A15 LED, E26 Medium Socket, 2700K
 Lamp Wattage: 10W
 Lamp Quantity: 1
 UL Listing: Fixture must be U.L. listed and so labeled
 Shade/Diff. Material: White linen wrapped shade with rolled edges
 Shade/Diff. Dims.: Top" 9 1/2" Dia. X Bottom 11 3/4" Dia. x 14"H
 Lamp Base: Base to feature felt protective non-skid padding secured to bottom.
 Dimmer: No
 Notes:

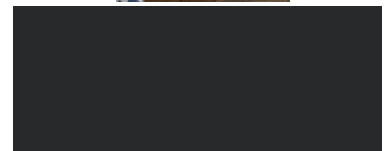
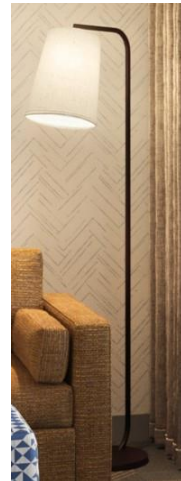

Metal Finish

Unless Using A Specified Manufacturer, Submit The Following Required Item(s) for Approval Prior to Fabrication:

Finish Sample **Shop Drawing**

Manufacturer to confirm the Product meets Hilton Design and Construction Standards as noted in Section 2515.00

Instructions:

- All quantities to be verified by hotel operator prior to purchasing.
- It is the responsibility of the owner to interpret these specifications for each property.
- All interpretations of the specification MUST be submitted to Hilton Design Review (projecthub.hilton.com) for final approval prior to purchasing or implementation of any material.
- Must be of contract quality and suitable for commercial use.
- All materials and methods of construction must comply with all local fire and life safety codes and Brand Standards.
- Fixture must be U.L. Listed and so labeled. Manufacturer is responsible for submitting all technical specifications for fire safety, UL standards, and any other specifications that are required to comply with local and state fire codes.
- Manufacturer/Fabricator to confirm weight of fixture.
- Show all pieces in scaled shop drawings. Entire fixture shall be inspected during the manufacturing and again after final assembly.
- Manufacturer to clearly mark each carton with item ID and specification number.

Project Name: Home2 Prototype FF&E Specifications Item Number: **(B) PA-204**
 Scheme: B-Dynamic Item Name: Wall Sconce @ Guest Corridor
 Issue Date: March-23 Area Name: Public Area - Guest Corridors
 Revisions: May-23 Δ1

Manufacturer:	Arkansas Lighting	Illumination Lighting	Trinity Lighting
Address:	1701 South 28th Street Van Buren, AR 72956	2300 Victoria Ave Lachine, Quebec H8S 1Z3	2902 Quality Way Jonesboro, AR 72401
Phone:	479-474-0876	514-634-7200 ext. 225	870-972-1177
Contact:	Maria Gunter	Annette Serrao	Sonja Hutchison
E-mail:	mgunter@arkansaslighting.com	annette@illuminationlighting.com	shutchison@trinitylighting.com
Web:	www.arkansaslighting.com	www.illuminationlighting.com	www.trinitylighting.com

Description: Direct/Indirect Corridor Wall Sconce
 Overall Dimensions: Overall width: 5"W; 14"H x 4" Max Depth
 Finish:
 Top Shade: Frosted white acrylic
 Bottom Shade: Exterior powdercoated to match Benjamin Moore paint color Blue Hydrangea 2062-60 matte finish, Interior powdercoated to match RAL 9010 Pure White matte finish
 Backplate: Stainless steel metal powdercoated to match RAL 9011 Graphite Black matte finish
 Switch Type: Hardwired
 Cord Length: NA
 Cord Color: NA
 Lamp Type: LED E26 medium socket 3000K
 Lamp Wattage: 11 W
 Lamp Quantity: 2
 UL Listing: Fixture must be U.L. listed and labeled
 Shade/Diff. Style: Cylinder
 Shade/Diff. Material: Top: Frosted white matte acrylic and powdercoated stainless steel metal, Bottom: Powdercoated stainless steel metal
 Shade/Diff. Dims.: 3 1/8"Dia x 6 5/8"H
 Mounting Instructions: Wall mounted, refer to architectural drawings for mounting height
 Notes: Manufacturer to provide mounting hardware and accessories

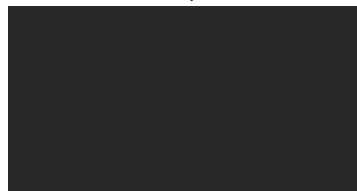
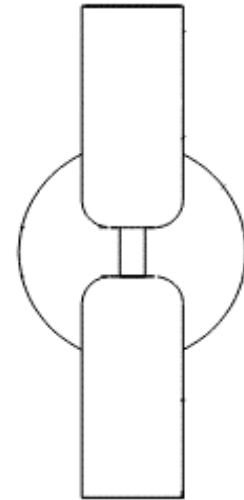

Backplate Finish

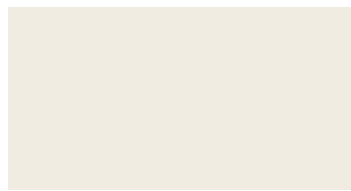

Interior Finish



Bottom Shade Finish

Unless Using A Specified Manufacturer, Submit The Following Required Item(s) for Approval Prior to Fabrication:

Finish Sample **Shop Drawing**

Manufacturer to confirm the Product meets Hilton Design and Construction Standards as noted in Section 2515.00

Instructions:

- All quantities to be verified by hotel operator prior to purchasing.
- It is the responsibility of the owner to interpret these specifications for each property.
- All interpretations of the specification MUST be submitted to Hilton Design Review (projecthub.hilton.com) for final approval prior to purchasing or implementation of any material.



Project Name: Home2 Prototype FF&E Specifications
Scheme: B-Dynamic
Issue Date: March-23
Revisions: May-23 Δ1

Item Number: **(B) PA-204**
Item Name: Wall Sconce @ Guest Corridor
Area Name: Public Area - Guest Corridors

-
- Must be of contract quality and suitable for commercial use.
 - All materials and methods of construction must comply with all local fire and life safety codes and Brand Standards.
 - Fixture must be U.L. Listed and so labeled. Manufacturer is responsible for submitting all technical specifications for fire safety, UL standards, and any other specifications that are required to comply with local and state fire codes.
 - Manufacturer/Fabricator to confirm weight of fixture.
 - Manufacturer/Fabricator to verify installation method and hanging points.
 - Show all pieces in scaled shop drawings. Entire fixture shall be inspected during the manufacturing and again after final assembly.
 - Manufacturer to clearly mark each carton with item ID and specification number.

Project Name: Home2 Prototype FF&E Specifications Item Number: **(B) PA-205**
 Scheme: B-Dynamic Item Name: Pendant Lighting @ Reception
 Issue Date: March-23 Area Name: Public Area - Reception
 Revisions: May-23 Δ1

Manufacturer:	Arkansas Lighting	Illumination Lighting	Trinity Lighting
Address:	1701 South 28th Street Van Buren, AR 72956	2300 Victoria Ave Lachine, Quebec H8S 1Z3	2902 Quality Way Jonesboro, AR 72401
Phone:	479-474-0876	514-634-7200 ext. 225	870-972-1177
Contact:	Maria Gunter	Annette Serrao	Sonja Hutchison
E-mail:	mgunter@arkansaslighting.com	annette@illuminationlighting.com	shutchison@trinitylighting.com
Web:	www.arkansaslighting.com	www.illuminationlighting.com	www.trinitylighting.com

Description: Pendant Lighting at Reception
 Overall Dimensions: 45"W x 36"H x 13.5"D
 Finish: Powdercoated stainless steel exterior to match Benjamin Moore paint color Blue Hydrangea 2062-60 matte finish, interior to match RAL 9010 Pure White
 Switch Type: Hardwired
 Cord Length: 72", adjustable in field
 Cord Color: Black cloth cord cover
 Lamp Type: A15 LED, E26 Medium Socket 3000K
 Lamp Wattage: 11W
 Lamp Quantity: 3
 UL Listing: Fixture must be U.L. listed and so labeled
 Shade/Diff. Style: Bell shape fixture, open at bottom
 Shade/Diff. Material: Powdercoated stainless steel
 Shade/Diff. Dims.: 13.5"Dia x 8"H
 Suspension Info: Refer to architectural drawings for mounting height and location
 Notes: Manufacturer to provide mounting hardware and accessories

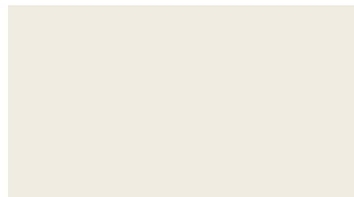
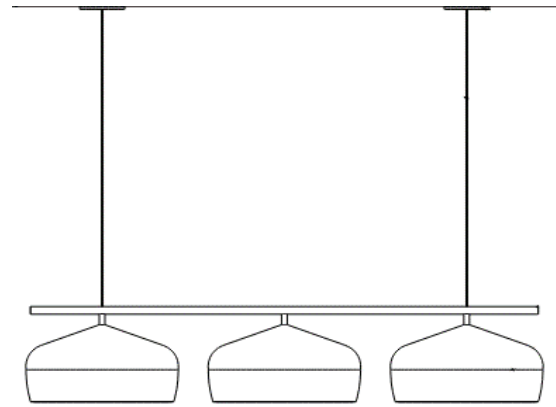

Interior Finish



Exterior Finish

Unless Using A Specified Manufacturer, Submit The Following Required Item(s) for Approval Prior to Fabrication:

Finish Sample **Shop Drawing**

Manufacturer to confirm the Product meets Hilton Design and Construction Standards as noted in Section 2515.00

Instructions:

- All quantities to be verified by hotel operator prior to purchasing.
- It is the responsibility of the owner to interpret these specifications for each property.
- All interpretations of the specification MUST be submitted to Hilton Design Review (projecthub.hilton.com) for final approval prior to purchasing or implementation of any material.
- Must be of contract quality and suitable for commercial use.
- All materials and methods of construction must comply with all local fire and life safety codes and Brand Standards.



Project Name: Home2 Prototype FF&E Specifications
Scheme: B-Dynamic
Issue Date: March-23
Revisions: May-23 Δ1

Item Number: **(B) PA-205**
Item Name: Pendant Lighting @ Reception
Area Name: Public Area - Reception

-
- Fixture must be U.L. Listed and so labeled. Manufacturer is responsible for submitting all technical specifications for fire safety, UL standards, and any other specifications that are required to comply with local and state fire codes.
 - Manufacturer/Fabricator to confirm weight of fixture.
 - Manufacturer/Fabricator to verify installation method and hanging points.
 - Show all pieces in scaled shop drawings. Entire fixture shall be inspected during the manufacturing and again after final assembly.
 - Manufacturer to clearly mark each carton with item ID and specification number.

Project Name: Home2 Prototype FF&E Specifications Item Number: **(B) PA-206**
 Scheme: B-Dynamic Item Name: Table Lamp at TV Lounge
 Issue Date: March-23 Area Name: Public Area - TV Lounge
 Revisions: May-23 Δ1

Manufacturer:	Arkansas Lighting	Illumination Lighting	Trinity Lighting
Address:	1701 South 28th Street Van Buren, AR 72956	2300 Victoria Ave Lachine, Quebec H8S 1Z3	2902 Quality Way Jonesboro, AR 72401
Phone:	479-474-0876	514-634-7200 ext. 225	870-972-1177
Contact:	Maria Gunter	Annette Serrao	Sonja Hutchison
E-mail:	mgunter@arkansaslighting.com	annette@illuminationlighting.com	shutchison@trinitylighting.com
Web:	www.arkansaslighting.com	www.illuminationlighting.com	www.trinitylighting.com

Description: Table Lamp at TV Lounge
 Overall Dimensions: 12" Dia x 21"H
 Finish: Resin to match RAL 9011 Black Graphite in matte finish
 Switch Type: On/Off rocker switch on stem, Finish: Black
 Cord Length: 96"
 Cord Color: Clear/Silver
 Plug Type: 90°/Right angle plug
 Lamp Type: A15 LED, E26 medium socket 2700K
 Lamp Wattage: 8.5W
 Lamp Quantity: 1
 UL Listing: Fixture must be U.L. listed and labeled
 Shade/Diff. Style: Seamless drum shade
 Shade/Diff. Material: White linen wrapped shade with rolled edges
 Shade/Diff. Dims.: Top: 11" Dia. X Bottom: 12"Dia. X 10"H
 Lamp Base: Base to feature felt protective non-skid padding secured to bottom.
 Base to be weighted.

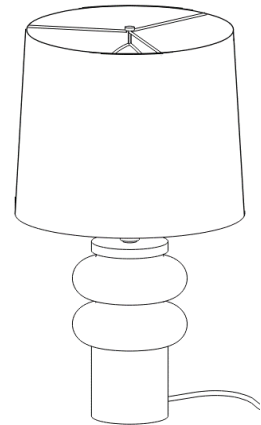

Resin Finish

Notes:

Unless Using A Specified Manufacturer, Submit The Following Required Item(s) for Approval Prior to Fabrication:

Finish Sample **Shop Drawing**

Manufacturer to confirm the Product meets Hilton Design and Construction Standards as noted in Section 2515.00

Instructions:

- All quantities to be verified by hotel operator prior to purchasing.
- It is the responsibility of the owner to interpret these specifications for each property.
- All interpretations of the specification MUST be submitted to Hilton Design Review (projecthub.hilton.com) for final approval prior to purchasing or implementation of any material.
- Must be of contract quality and suitable for commercial use.
- All materials and methods of construction must comply with all local fire and life safety codes and Brand Standards.
- Fixture must be U.L. Listed and so labeled. Manufacturer is responsible for submitting all technical specifications for fire safety, UL standards, and any other specifications that are required to comply with local and state fire codes.
- Manufacturer/Fabricator to confirm weight of fixture.
- Manufacturer/Fabricator to verify installation method and hanging points.
- Show all pieces in scaled shop drawings. Entire fixture shall be inspected during the manufacturing and again after final assembly.
- Manufacturer to clearly mark each carton with item ID and specification number.

Project Name: Home2 Prototype FF&E Specifications
 Scheme: B-Dynamic
 Issue Date: March-23
 Revisions: May-23 Δ1

Item Number: **(B) PA-300**
 Item Name: Square 2 Top Dining Table
 Area Name: Public Area - Lobby

Manufacturer:	MTS Seating	Baltix Sustainable Furniture, LLC	Shelby Williams
Address:	7100 Industrial Drive Temperance, MI 481182	434 Lake Street, Suite 203 Excelsior, MN 55331	810 West Highway 25/70 Newport, TN 37821
Phone:	734-847-3875	952-698-1220	800-873-3252
Contact:	Lisa McAfee	Alexander Lodge	Jordan McInturf
E-mail:	lisamcafee@mtsseating.com	alexander@baltix.com	jmcinturf@mycgroup.com.com
Web:	www.mtsseating.com	www.baltix.com	www.shelbywilliams.com

Description: Square 2 Top Dining Table with "X" Base
 Width: 24"
 Depth: 24"
 Height: 29"
 Top Thickness: 1 1/2"
 Top Material/Finish: Plastic laminate top to match PL-02 Wilsonart High Line 7970K-18 Linearity Finish with Aeon
 Edge Detail: 3 mm edgebanding to match PL-02 Wilsonart High Line 7970K-18 Linearity Finish with Aeon
 Base Material/Finish: Powder-coated metal to match TIGER Drylac Satin Jet Black 38/80020 in matte finish
 Data/Electrical: NA
 Notes: Provide heavy duty adjustable nylon glides.

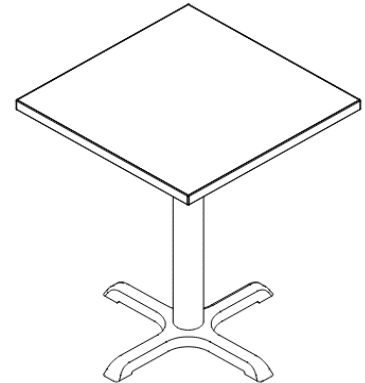

Metal Finish



PL-02

Unless Using A Specified Manufacturer, Submit The Following Required Item(s) for Approval Prior to Fabrication:

Finish Sample **Shop Drawing**

Manufacturer to confirm the Product meets Hilton Design and Construction Standards as noted in Section 2515.00

Instructions:

- All quantities to be verified by hotel operator prior to purchasing.
- It is the responsibility of the owner to interpret these specifications for each property.
- All interpretations of the specification MUST be submitted to Hilton Design Review (projecthub.hilton.com) for final approval prior to purchasing or implementation of any material.
- Must be of contract quality and suitable for commercial use.
- All materials and methods of construction must comply with all local fire and life safety codes and Brand Standards.
- Manufacturer to provide all necessary hardware for each item. All internal hardware (hinges, screws, bolts, etc.) shall be corrosion proof.
- Major joints as needed shall utilize lap joints or double doweled construction with corner blocks. Glue and staples are used to reinforce the joinery.
- Metal fasteners should be used where appropriate to ensure commercial frame strength.
- Manufacturer to verify all necessary parts, hardware and dimensions required for assembly.
- All wood to be kiln dried and treated to be insect and vermin free.



Project Name: Home2 Prototype FF&E Specifications
Scheme: B-Dynamic
Issue Date: March-23
Revisions: May-23 Δ1

Item Number: **(B) PA-300**
Item Name: Square 2 Top Dining Table
Area Name: Public Area - Lobby

-
- Ensure that all pieces will fit in elevators and through doors prior to commencing fabrication.
 - Show all pieces in shop drawings. Provide reproducible scaled shop drawings to Hotel Operator Representative prior to production.
 - Provide clear alcohol and water-resistant penetrating sealer as required at wood.
 - Solid hardwood frames to be certified sustainable sources. All stress joints to be connected by double doweled, screwed and glued corner reinforcement.
 - All corners of metal frame to be mitered; All welds to be filled and fully finished; Grind and smooth all edges; No visible welds, seams, or burn marks; Seal as required.
 - Finish goods containing composite wood products must comply with California Code of Regulations 93120. Product and carton will be labeled in accordance with this regulation.
 - Manufacturer to clearly mark each carton with item ID and specification number.

Project Name: Home2 Prototype FF&E Specifications
 Scheme: B-Dynamic
 Issue Date: March-23
 Revisions: May-23 Δ1

Item Number: **(B) PA-301**
 Item Name: Round 2 Top Dining Table
 Area Name: Public Area - Lobby

Manufacturer:	MTS Seating	Baltix Sustainable Furniture, LLC	Shelby Williams
Address:	7100 Industrial Drive Temperance, MI 481182	434 Lake Street, Suite 203 Excelsior, MN 55331	810 West Highway 25/70 Newport, TN 37821
Phone:	734-847-3875	952-698-1220	800-873-3252
Contact:	Lisa McAfee	Alexander Lodge	Jordan McInturf
E-mail:	lisamcafee@mtsseating.com	alexander@baltix.com	jmcinturf@mycgroup.com.com
Web:	www.mtsseating.com	www.baltix.com	www.shelbywilliams.com

Description: Pedestal Base Round Top Dining Table
 Width: 27 1/2" Dia.
 Depth: 27 1/2" Dia.
 Height: 29"
 Top Thickness: 1 1/2"
 Top Material/Finish: Plastic laminate top to match PL-02 Wilsonart High Line 7970K-18 Linearity Finish with Aeon
 Edge Detail: 3 mm edgebanding to match PL-02 Wilsonart High Line 7970K-18 Linearity Finish with Aeon
 Base Material/Finish: Powder-coated metal to match TIGER Drylac Satin Jet Black 38/80020 in matte finish
 Data/Electrical: NA
 Notes: Provide heavy duty adjustable nylon glides.

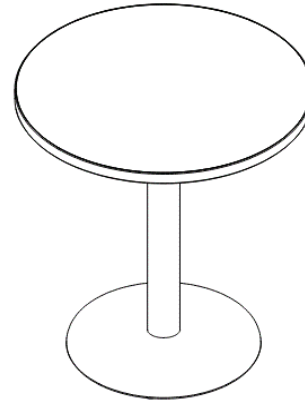

Metal Finish



PL-02

Unless Using A Specified Manufacturer, Submit The Following Required Item(s) for Approval Prior to Fabrication:
Finish Sample **Shop Drawing**

Manufacturer to confirm the Product meets Hilton Design and Construction Standards as noted in Section 2515.00

Instructions:

- All quantities to be verified by hotel operator prior to purchasing.
- It is the responsibility of the owner to interpret these specifications for each property.
- All interpretations of the specification MUST be submitted to Hilton Design Review (projecthub.hilton.com) for final approval prior to purchasing or implementation of any material.
- Must be of contract quality and suitable for commercial use.
- All materials and methods of construction must comply with all local fire and life safety codes and Brand Standards.
- Manufacturer to provide all necessary hardware for each item. All internal hardware (hinges, screws, bolts, etc.) shall be corrosion proof.
- Major joints as needed shall utilize lap joints or double doweled construction with corner blocks. Glue and staples are used to reinforce the joinery.
- Metal fasteners should be used where appropriate to ensure commercial frame strength.
- Manufacturer to verify all necessary parts, hardware and dimensions required for assembly.



Project Name: Home2 Prototype FF&E Specifications
Scheme: B-Dynamic
Issue Date: March-23
Revisions: May-23 Δ1

Item Number: **(B) PA-301**
Item Name: Round 2 Top Dining Table
Area Name: Public Area - Lobby

-
- All wood to be kiln dried and treated to be insect and vermin free.
 - Ensure that all pieces will fit in elevators and through doors prior to commencing fabrication.
 - Show all pieces in shop drawings. Provide reproducible scaled shop drawings to Hotel Operator Representative prior to production.
 - Provide clear alcohol and water-resistant penetrating sealer as required at wood.
 - Solid hardwood frames to be certified sustainable sources. All stress joints to be connected by double doweled, screwed and glued corner reinforcement.
 - All corners of metal frame to be mitered; All welds to be filled and fully finished; Grind and smooth all edges; No visible welds, seams, or burn marks; Seal as required.
 - Finish goods containing composite wood products must comply with California Code of Regulations 93120. Product and carton will be labeled in accordance with this regulation.
 - Manufacturer to clearly mark each carton with item ID and specification number.

Project Name: Home2 Prototype FF&E Specifications
 Scheme: B-Dynamic
 Issue Date: March-23
 Revisions: May-23 Δ1

Item Number: **(B) PA-302**
 Item Name: Rectangular 4 Top Dining Table
 Area Name: Public Area - Lobby

Manufacturer:	MTS Seating	Baltix Sustainable Furniture, LLC	Shelby Williams
Address:	7100 Industrial Drive Temperance, MI 481182	434 Lake Street, Suite 203 Excelsior, MN 55331	810 West Highway 25/70 Newport, TN 37821
Phone:	734-847-3875	952-698-1220	800-873-3252
Contact:	Lisa McAfee	Alexander Lodge	Jordan McInturf
E-mail:	lisamcafee@mtsseating.com	alexander@baltix.com	jmcinturf@mycgroup.com.com
Web:	www.mtsseating.com	www.baltix.com	www.shelbywilliams.com

Description: Rectangular 4 Top Dining Table
 Width: 24"
 Depth: 48"
 Height: 30"
 Top Thickness: 1 1/2"
 Top Material/Finish: Plastic laminate top to match PL-02 Wilsonart High Line 7970K-18 Linearity Finish with Aeon
 Edge Detail: 3 mm edgebanding to match PL-02 Wilsonart High Line 7970K-18 Linearity Finish with Aeon
 Base Material/Finish: Powder-coated metal to match TIGER Drylac Sparkle Silver Glossy 49/90450
 Data/Electrical: NA
 Notes: Provide heavy duty adjustable nylon glides.

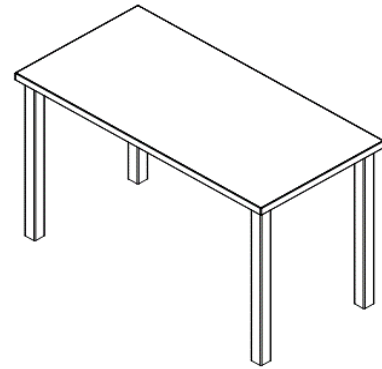

Metal Finish



PL-02

Unless Using A Specified Manufacturer, Submit The Following Required Item(s) for Approval Prior to Fabrication:

Finish Sample **Shop Drawing**

Manufacturer to confirm the Product meets Hilton Design and Construction Standards as noted in Section 2515.00

Instructions:

- All quantities to be verified by hotel operator prior to purchasing.
- It is the responsibility of the owner to interpret these specifications for each property.
- All interpretations of the specification MUST be submitted to Hilton Design Review (projecthub.hilton.com) for final approval prior to purchasing or implementation of any material.
- Must be of contract quality and suitable for commercial use.
- All materials and methods of construction must comply with all local fire and life safety codes and Brand Standards.
- Manufacturer to provide all necessary hardware for each item. All internal hardware (hinges, screws, bolts, etc.) shall be corrosion proof.
- Major joints as needed shall utilize lap joints or double doweled construction with corner blocks. Glue and staples are used to reinforce the joinery.
- Metal fasteners should be used where appropriate to ensure commercial frame strength.
- Manufacturer to verify all necessary parts, hardware and dimensions required for assembly.
- All wood to be kiln dried and treated to be insect and vermin free.



Project Name: Home2 Prototype FF&E Specifications
Scheme: B-Dynamic
Issue Date: March-23
Revisions: May-23 Δ1

Item Number: **(B) PA-302**
Item Name: Rectangular 4 Top Dining Table
Area Name: Public Area - Lobby

-
- Ensure that all pieces will fit in elevators and through doors prior to commencing fabrication.
 - Show all pieces in shop drawings. Provide reproducible scaled shop drawings to Hotel Operator Representative prior to production.
 - Provide clear alcohol and water-resistant penetrating sealer as required at wood.
 - Solid hardwood frames to be certified sustainable sources. All stress joints to be connected by double doweled, screwed and glued corner reinforcement.
 - All corners of metal frame to be mitered; All welds to be filled and fully finished; Grind and smooth all edges; No visible welds, seams, or burn marks; Seal as required.
 - Finish goods containing composite wood products must comply with California Code of Regulations 93120. Product and carton will be labeled in accordance with this regulation.
 - Manufacturer to clearly mark each carton with item ID and specification number.

Project Name: Home2 Prototype FF&E Specifications
 Scheme: B-Dynamic
 Issue Date: March-23
 Revisions: May-23 Δ1

Item Number: **(B) PA-303**
 Item Name: Tea Height Round Table
 Area Name: Public Area - Lobby

Manufacturer:	MTS Seating	Baltix Sustainable Furniture, LLC	Shelby Williams
Address:	7100 Industrial Drive Temperance, MI 481182	434 Lake Street, Suite 203 Excelsior, MN 55331	810 West Highway 25/70 Newport, TN 37821
Phone:	734-847-3875	952-698-1220	800-873-3252
Contact:	Lisa McAfee	Alexander Lodge	Jordan McInturf
E-mail:	lisamcafee@mtsseating.com	alexander@baltix.com	jmcinturf@mycgroup.com.com
Web:	www.mtsseating.com	www.baltix.com	www.shelbywilliams.com

Description: Tea Height Round Table
 Width: 24" Dia.
 Depth: 24" Dia.
 Height: 27"
 Top Thickness: 1 1/2"
 Edge Detail: 3 mm edgebanding to match Wilsonart Black 1595-05
 Top Material/Finish: Plastic laminate to match Wilsonart Black 1595-05
 Base Material/Finish: Powder-coated metal to match TIGER Drylac Satin Jet Black 38/80020
 Data/Electrical: NA
 Notes: Provide heavy duty adjustable nylon glides.

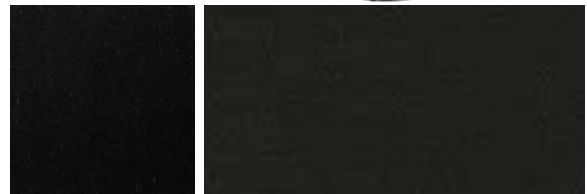
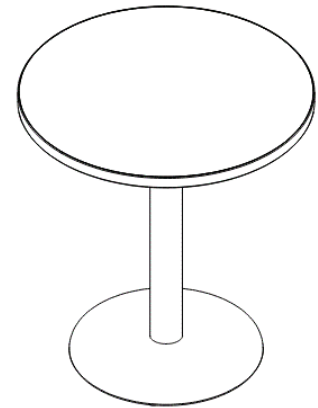

Metal Finish

Top Finish

Unless Using A Specified Manufacturer, Submit The Following Required Item(s) for Approval Prior to Fabrication:
Finish Sample **Shop Drawing**

Manufacturer to confirm the Product meets Hilton Design and Construction Standards as noted in Section 2515.00

Instructions:

- All quantities to be verified by hotel operator prior to purchasing.
- It is the responsibility of the owner to interpret these specifications for each property.
- All interpretations of the specification MUST be submitted to Hilton Design Review (projecthub.hilton.com) for final approval prior to purchasing or implementation of any material.
- Must be of contract quality and suitable for commercial use.
- All materials and methods of construction must comply with all local fire and life safety codes and Brand Standards.
- Manufacturer to provide all necessary hardware for each item. All internal hardware (hinges, screws, bolts, etc.) shall be corrosion proof.
- Major joints as needed shall utilize lap joints or double doweled construction with corner blocks. Glue and staples are used to reinforce the joinery.
- Metal fasteners should be used where appropriate to ensure commercial frame strength.
- Manufacturer to verify all necessary parts, hardware and dimensions required for assembly.



Project Name: Home2 Prototype FF&E Specifications
Scheme: B-Dynamic
Issue Date: March-23
Revisions: May-23 Δ1

Item Number: **(B) PA-303**
Item Name: Tea Height Round Table
Area Name: Public Area - Lobby

-
- All wood to be kiln dried and treated to be insect and vermin free.
 - Ensure that all pieces will fit in elevators and through doors prior to commencing fabrication.
 - Show all pieces in shop drawings. Provide reproducible scaled shop drawings to Hotel Operator Representative prior to production.
 - Provide clear alcohol and water-resistant penetrating sealer as required at wood.
 - Solid hardwood frames to be certified sustainable sources. All stress joints to be connected by double doweled, screwed and glued corner reinforcement.
 - All corners of metal frame to be mitered; All welds to be filled and fully finished; Grind and smooth all edges; No visible welds, seams, or burn marks; Seal as required.
 - Finish goods containing composite wood products must comply with California Code of Regulations 93120. Product and carton will be labeled in accordance with this regulation.
 - Manufacturer to clearly mark each carton with item ID and specification number.

Project Name: Home2 Prototype FF&E Specifications
 Scheme: B-Dynamic
 Issue Date: March-23

Item Number: **(B) PA-304**
 Item Name: Laptop Table
 Area Name: Public Area - Lobby & TV Lounge

Revisions:

Manufacturer:	Elkay Interior Systems	D'Style Inc
Address:	1 Mid America Plaza, Floor 3 Oakbrook Terrace, IL 60181	3451 Main Street, Suite 108 Chula Vista, CA 91911
Phone:	414-224-0957	619-662-0560 ext.136
Contact:	Courtney Messersmith	Eric Constantino
E-mail:	hospitalitybids@elkayinteriorsystems.com	dsquotes@dstyle.com.com
Web:	www.elkayinteriorsystems.com	www.dstyleinc.com

Description: Laptop Table
 Width: 20"
 Depth: 15"
 Height: 25"
 Top Material/Finish: Plastic laminate top to match PL-01 Wilsonart 5th Ave Elm 7966K-12 Soft Grain Texture with Aeon
 Base Material/Finish: Powder-coated metal to match TIGER Drylac Satin Jet Black 38/80020 in matte finish
 Notes: Provide heavy duty adjustable nylon glides.

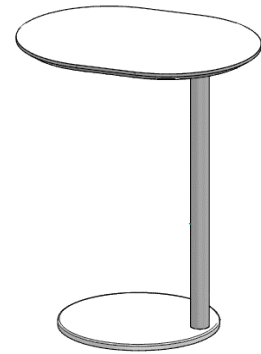

Metal Finish



PL-01

Unless Using A Specified Manufacturer, Submit The Following Required Item(s) for Approval Prior to Fabrication:

Finish Sample **Shop Drawing**

Manufacturer to confirm the Product meets Hilton Design and Construction Standards as noted in Section 2515.00

Instructions:

- All quantities to be verified by hotel operator prior to purchasing.
- It is the responsibility of the owner to interpret these specifications for each property.
- All interpretations of the specification MUST be submitted to Hilton Design Review (projecthub.hilton.com) for final approval prior to purchasing or implementation of any material.
- Must be of contract quality and suitable for commercial use.
- All materials and methods of construction must comply with all local fire and life safety codes and Brand Standards.
- Manufacturer to provide all necessary hardware for each item. All internal hardware (hinges, screws, bolts, etc.) shall be corrosion proof.
- Major joints as needed shall utilize lap joints or double doweled construction with corner blocks. Glue and staples are used to reinforce the joinery.
- Metal fasteners should be used where appropriate to ensure commercial frame strength.
- Manufacturer to verify all necessary parts, hardware and dimensions required for assembly.
- All wood to be kiln dried and treated to be insect and vermin free.
- Ensure that all pieces will fit in elevators and through doors prior to commencing fabrication.



Project Name: Home2 Prototype FF&E Specifications
Scheme: B-Dynamic
Issue Date: March-23

Item Number: **(B) PA-304**
Item Name: Laptop Table
Area Name: Public Area - Lobby & TV Lounge

Revisions:

- Show all pieces in shop drawings. Provide reproducible scaled shop drawings to Hotel Operator Representative prior to production.
- Provide clear alcohol and water-resistant penetrating sealer as required at wood.
- Solid hardwood frames to be certified sustainable sources. All stress joints to be connected by double doweled, screwed and glued corner reinforcement.
- All corners of metal frame to be mitered; All welds to be filled and fully finished; Grind and smooth all edges; No visible welds, seams, or burn marks; Seal as required.
- Finish goods containing composite wood products must comply with California Code of Regulations 93120. Product and carton will be labeled in accordance with this regulation.
- Manufacturer to clearly mark each carton with item ID and specification number.

Project Name: Home2 Prototype FF&E Specifications
 Scheme: B-Dynamic
 Issue Date: March-23
 Revisions: May-23 Δ1

Item Number: **(B) PA-305**
 Item Name: Square Side Table
 Area Name: Public Area - TV Lounge

Manufacturer:	Elkay Interior Systems	D'Style Inc
Address:	1 Mid America Plaza, Floor 3 Oakbrook Terrace, IL 60181	3451 Main Street, Suite 108 Chula Vista, CA 91911
Phone:	414-224-0957	619-662-0560 ext.136
Contact:	Courtney Messersmith	Eric Constantino
E-mail:	hospitalitybids@elkayinteriorsystems.com	dsquotes@dstyle.com.com
Web:	www.elkayinteriorsystems.com	www.dstyleinc.com

Description: Square Side Table
 Width: 29"
 Depth: 29"
 Height: 18"
 Top Thickness: 1 1/2"
 Top Material/Finish: Plastic laminate top to match PL-02 Wilsonart High Line 7970K-18 Linearity Finish with Aeon
 Edge Detail: 2 mm edgebanding to match PL-02 Wilsonart High Line 7970K-18 Linearity Finish with Aeon
 Base Material/Finish: Powder-coated metal, RAL 9004 black, satin finish
 Base Frame Dim. 1"w x 2"d x 2"h
 Notes: Provide heavy duty adjustable nylon glides.

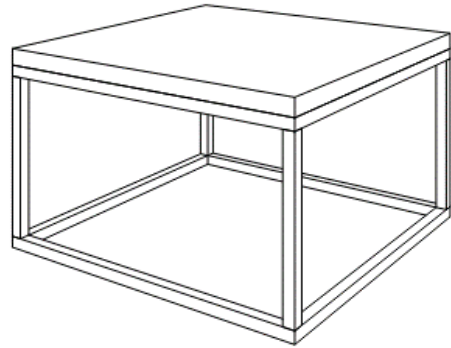

Metal Finish



PL-02

Unless Using A Specified Manufacturer, Submit The Following Required Item(s) for Approval Prior to Fabrication:

Finish Sample **Shop Drawing**

Manufacturer to confirm the Product meets Hilton Design and Construction Standards as noted in Section 2515.00

Instructions:

- All quantities to be verified by hotel operator prior to purchasing.
- It is the responsibility of the owner to interpret these specifications for each property.
- All interpretations of the specification MUST be submitted to Hilton Design Review (projecthub.hilton.com) for final approval prior to purchasing or implementation of any material.
- Must be of contract quality and suitable for commercial use.
- All materials and methods of construction must comply with all local fire and life safety codes and Brand Standards.
- Manufacturer to provide all necessary hardware for each item. All internal hardware (hinges, screws, bolts, etc.) shall be corrosion proof.
- Major joints as needed shall utilize lap joints or double doweled construction with corner blocks. Glue and staples are used to reinforce the joinery.
- Metal fasteners should be used where appropriate to ensure commercial frame strength.
- Manufacturer to verify all necessary parts, hardware and dimensions required for assembly.
- All wood to be kiln dried and treated to be insect and vermin free.
- Ensure that all pieces will fit in elevators and through doors prior to commencing fabrication.



Project Name: Home2 Prototype FF&E Specifications
Scheme: B-Dynamic
Issue Date: March-23
Revisions: May-23 Δ1

Item Number: **(B) PA-305**
Item Name: Square Side Table
Area Name: Public Area - TV Lounge

-
- Show all pieces in shop drawings. Provide reproducible scaled shop drawings to Hotel Operator Representative prior to production.
 - Provide clear alcohol and water-resistant penetrating sealer as required at wood.
 - Solid hardwood frames to be certified sustainable sources. All stress joints to be connected by double doweled, screwed and glued corner reinforcement.
 - All corners of metal frame to be mitered; All welds to be filled and fully finished; Grind and smooth all edges; No visible welds, seams, or burn marks; Seal as required.
 - Finish goods containing composite wood products must comply with California Code of Regulations 93120. Product and carton will be labeled in accordance with this regulation.
 - Manufacturer to clearly mark each carton with item ID and specification number.

Project Name: Home2 Prototype FF&E Specifications
 Scheme: B-Dynamic
 Issue Date: March-23
 Revisions: May-23 Δ1

Item Number: **(B) PA-306**
 Item Name: Dining Table @ Booth
 Area Name: Public Area - Lobby

Manufacturer:	MTS Seating	Baltix Sustainable Furniture, LLC	Shelby Williams
Address:	7100 Industrial Drive Temperance, MI 481182	434 Lake Street, Suite 203 Excelsior, MN 55331	810 West Highway 25/70 Newport, TN 37821
Phone:	734-847-3875	952-698-1220	800-873-3252
Contact:	Lisa McAfee	Alexander Lodge	Jordan McInturf
E-mail:	lisamcafee@mtsseating.com	alexander@baltix.com	jmcinturf@mycgroup.com.com
Web:	www.mtsseating.com	www.baltix.com	www.shelbywilliams.com

Description: Pedestal Base Rectangular Dining Table
 Width: 42"
 Depth: 36"
 Height: 29"
 Top Thickness: 1 1/2"
 Top Material/Finish: Plastic laminate top to match PL-02 Wilsonart High Line 7970K-18 Linearity Finish with Aeon
 Edge Detail: 3 mm edgebanding to match PL-02 Wilsonart High Line 7970K-18 Linearity Finish with Aeon
 Base Material/Finish: Powder-coated metal to match TIGER Drylac Satin Jet Black 38/80020 in matte finish
 Data/Electrical: NA
 Notes: Provide heavy duty adjustable nylon glides.

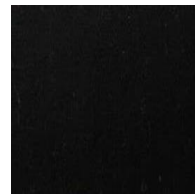
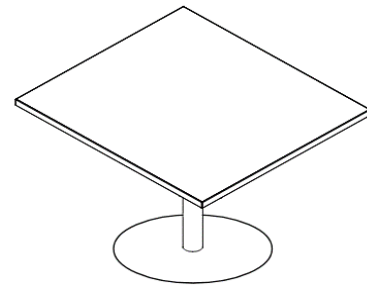

Metal Finish



PL-02

Unless Using A Specified Manufacturer, Submit The Following Required Item(s) for Approval Prior to Fabrication:

Finish Sample **Shop Drawing**

Manufacturer to confirm the Product meets Hilton Design and Construction Standards as noted in Section 2515.00

Instructions:

- All quantities to be verified by hotel operator prior to purchasing.
- It is the responsibility of the owner to interpret these specifications for each property.
- All interpretations of the specification MUST be submitted to Hilton Design Review (projecthub.hilton.com) for final approval prior to purchasing or implementation of any material.
- Must be of contract quality and suitable for commercial use.
- All materials and methods of construction must comply with all local fire and life safety codes and Brand Standards.
- Manufacturer to provide all necessary hardware for each item. All internal hardware (hinges, screws, bolts, etc.) shall be corrosion proof.
- Major joints as needed shall utilize lap joints or double doweled construction with corner blocks. Glue and staples are used to reinforce the joinery.
- Metal fasteners should be used where appropriate to ensure commercial frame strength.
- Manufacturer to verify all necessary parts, hardware and dimensions required for assembly.
- All wood to be kiln dried and treated to be insect and vermin free.
- Ensure that all pieces will fit in elevators and through doors prior to commencing fabrication.



Project Name: Home2 Prototype FF&E Specifications
Scheme: B-Dynamic
Issue Date: March-23
Revisions: May-23 Δ1

Item Number: **(B) PA-306**
Item Name: Dining Table @ Booth
Area Name: Public Area - Lobby

-
- Show all pieces in shop drawings. Provide reproducible scaled shop drawings to Hotel Operator Representative prior to production.
 - Provide clear alcohol and water-resistant penetrating sealer as required at wood.
 - Solid hardwood frames to be certified sustainable sources. All stress joints to be connected by double doweled, screwed and glued corner reinforcement.
 - All corners of metal frame to be mitered; All welds to be filled and fully finished; Grind and smooth all edges; No visible welds, seams, or burn marks; Seal as required.
 - Finish goods containing composite wood products must comply with California Code of Regulations 93120. Product and carton will be labeled in accordance with this regulation.
 - Manufacturer to clearly mark each carton with item ID and specification number.

Project Name: Home2 Prototype FF&E Specifications
 Scheme: B-Dynamic
 Issue Date: March-23
 Revisions: May-23 Δ1

Item Number: **(B) PA-307**
 Item Name: ADA Dining Table
 Area Name: Public Area - Lobby

Manufacturer:	MTS Seating	Baltix Sustainable Furniture, LLC
Address:	7100 Industrial Drive Temperance, MI 481182	434 Lake Street, Suite 203 Excelsior, MN 55331
Phone:	734-847-3875	952-698-1220
Contact:	Lisa McAfee	Alexander Lodge
E-mail:	lisamcafee@mtsseating.com	alexander@baltix.com
Web:	www.mtsseating.com	www.baltix.com

Description: Accessible 2 Top Rectangular Table with "T" Shaped Metal Base

Width: 42"
 Depth: 30"
 Height: 30"
 Top Thickness: 1 1/2"
 Top Material/Finish: Plastic laminate top to match PL-02 Wilsonart High Line 7970K-18 Linearity Finish with Aeon
 Edge Detail: 3 mm edgebanding to match PL-02 Wilsonart High Line 7970K-18 Linearity Finish with Aeon
 Base Material/Finish: Powder-coated metal to match TIGER Drylac Satin Jet Black 38/80020 in matte finish
 Data/Electrical: NA
 Notes: Provide heavy duty adjustable nylon glides.
 Must have 30" clear between table legs.

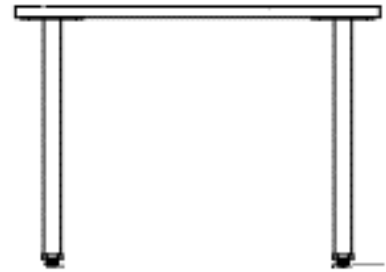

Metal Finish



PL-02

Unless Using A Specified Manufacturer, Submit The Following Required Item(s) for Approval Prior to Fabrication:

Finish Sample **Shop Drawing**

Manufacturer to confirm the Product meets Hilton Design and Construction Standards as noted in Section 2515.00

Instructions:

- All quantities to be verified by hotel operator prior to purchasing.
- It is the responsibility of the owner to interpret these specifications for each property.
- All interpretations of the specification MUST be submitted to Hilton Design Review (projecthub.hilton.com) for final approval prior to purchasing or implementation of any material.
- Must be of contract quality and suitable for commercial use.
- All materials and methods of construction must comply with all local fire and life safety codes and Brand Standards.
- Manufacturer to provide all necessary hardware for each item. All internal hardware (hinges, screws, bolts, etc.) shall be corrosion proof.
- Major joints as needed shall utilize lap joints or double doweled construction with corner blocks. Glue and staples are used to reinforce the joinery.
- Metal fasteners should be used where appropriate to ensure commercial frame strength.
- Manufacturer to verify all necessary parts, hardware and dimensions required for assembly.
- All wood to be kiln dried and treated to be insect and vermin free.
- Ensure that all pieces will fit in elevators and through doors prior to commencing fabrication.



Project Name: Home2 Prototype FF&E Specifications
Scheme: B-Dynamic
Issue Date: March-23
Revisions: May-23 Δ1

Item Number: **(B) PA-307**
Item Name: ADA Dining Table
Area Name: Public Area - Lobby

-
- Show all pieces in shop drawings. Provide reproducible scaled shop drawings to Hotel Operator Representative prior to production.
 - Provide clear alcohol and water-resistant penetrating sealer as required at wood.
 - Solid hardwood frames to be certified sustainable sources. All stress joints to be connected by double doweled, screwed and glued corner reinforcement.
 - All corners of metal frame to be mitered; All welds to be filled and fully finished; Grind and smooth all edges; No visible welds, seams, or burn marks; Seal as required.
 - Finish goods containing composite wood products must comply with California Code of Regulations 93120. Product and carton will be labeled in accordance with this regulation.
 - Manufacturer to clearly mark each carton with item ID and specification number.

Project Name: Home2 Prototype FF&E Specifications
 Scheme: B-Dynamic
 Issue Date: March-23
 Revisions: June-23 Δ2

Item Number: **(B) PA-308**
 Item Name: Media Credenza @ TV Lounge
 Area Name: Public Area - TV Lounge

Manufacturer:	Elkay Interior Systems	D'Style Inc
Address:	1 Mid America Plaza, Floor 3 Oakbrook Terrace, IL 60181	3451 Main Street, Suite 108 Chula Vista, CA 91911
Phone:	414-224-0957	619-662-0560 ext.136
Contact:	Courtney Messersmith	Eric Constantino
E-mail:	hospitalitybids@elkayinteriorsystems.com	dsquotes@dstyle.com.com
Web:	www.elkayinteriorsystems.com	www.dstyleinc.com

Description: Media Credenza at TV Lounge with Four Doors, Adjustable Shelves, and Metal Base

Width: 82"
 Depth: 20"
 Height: 34"
 Top Thickness: 1"
 Edge Detail: Square
 Hardware Style: 8" bar pull powder-coated to match RAL 9004 in matte finish

Top Material/Finish: Plastic Laminate, Finish to match PL-02 Wilsonart High Line 7970K-18 Linearity Finish with Aeon

Base Material/Finish: Plastic Laminate, Finish to match PL-02 Wilsonart High Line 7970K-18 Linearity Finish with Aeon

Data/Electrical: NA

Notes: Provide heavy duty adjustable nylon glides.

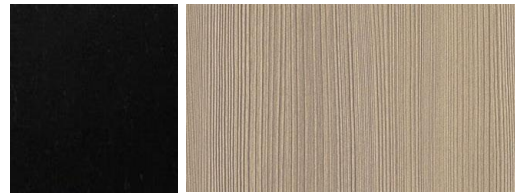
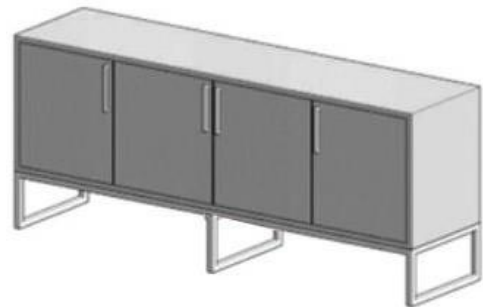

Metal Finish

PL-02

Unless Using A Specified Manufacturer, Submit The Following Required Item(s) for Approval Prior to Fabrication:

Finish Sample **Shop Drawing**

Manufacturer to confirm the Product meets Hilton Design and Construction Standards as noted in Section 2515.00

Instructions:

- All quantities to be verified by hotel operator prior to purchasing.
- It is the responsibility of the owner to interpret these specifications for each property.
- All interpretations of the specification MUST be submitted to Hilton Design Review (projecthub.hilton.com) for final approval prior to purchasing or implementation of any material.
- Must be of contract quality and suitable for commercial use.
- All materials and methods of construction must comply with all local fire and life safety codes and Brand Standards.
- Manufacturer to provide all necessary hardware for each item. All internal hardware (hinges, screws, bolts, etc.) shall be corrosion proof.
- Major joints as needed shall utilize lap joints or double doweled construction with corner blocks. Glue and staples are used to reinforce the joinery.
- Metal fasteners should be used where appropriate to ensure commercial frame strength.
- Manufacturer to verify all necessary parts, hardware and dimensions required for assembly.
- All wood to be kiln dried and treated to be insect and vermin free.
- Ensure that all pieces will fit in elevators and through doors prior to commencing fabrication.



Project Name: Home2 Prototype FF&E Specifications
Scheme: B-Dynamic
Issue Date: March-23
Revisions: June-23 Δ2

Item Number: **(B) PA-308**
Item Name: Media Credenza @ TV Lounge
Area Name: Public Area - TV Lounge

-
- Show all pieces in shop drawings. Provide reproducible scaled shop drawings to Hotel Operator Representative prior to production.
 - Provide clear alcohol and water-resistant penetrating sealer as required at wood.
 - Solid hardwood frames to be certified sustainable sources. All stress joints to be connected by double doweled, screwed and glued corner reinforcement.
 - All corners of metal frame to be mitered; All welds to be filled and fully finished; Grind and smooth all edges; No visible welds, seams, or burn marks; Seal as required.
 - Finish goods containing composite wood products must comply with California Code of Regulations 93120. Product and carton will be labeled in accordance with this regulation.
 - Manufacturer to clearly mark each carton with item ID and specification number.

Project Name:	Home2 Prototype FF&E Specifications		Item Number:	(B) PA-309
Scheme:	B-Dynamic		Item Name:	Breakroom Dining Table @ Employee Breakroom
Issue Date:	March-23		Area Name:	Breakroom
Revisions:	May-23	Δ1		
Manufacturer:	MTS Seating	Baltix Sustainable Furniture, LLC	Shelby Williams	
Address:	7100 Industrial Drive Temperance, MI 481182	434 Lake Street, Suite 203 Excelsior, MN 55331	810 West Highway 25/70 Newport, TN 37821	
Phone:	734-847-3875	952-698-1220	800-873-3252	
Contact:	Lisa McAfee	Alexander Lodge	Jordan McInturf	
E-mail:	lisamcafee@mtsseating.com	alexander@baltix.com	jmcinturf@mycgroup.com.com	
Web:	www.mtsseating.com	www.baltix.com	www.shelbywilliams.com	

Description: Breakroom Table with Metal Base
 Width: 72"
 Depth: 30"
 Height: 28 1/2"
 Top Material/Finish: Plastic laminate top to match PL-01 Wilsonart 5th Ave Elm 7966K-12 Soft Grain Texture with Aeon
 Edge Detail: 3 mm edgebanding to match PL-01 Wilsonart 5th Ave Elm 7966K-12 Soft Grain Texture with Aeon
 Base Material/Finish: Powder-coated metal to match TIGER Drylac Satin Jet Black 38/80020 in matte finish
 Notes: Provide heavy duty adjustable nylon glides.

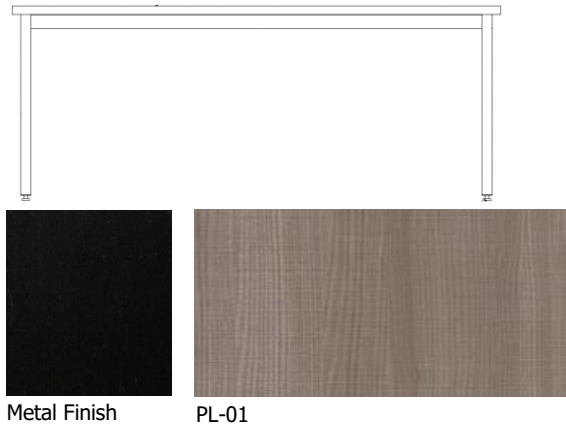

Unless Using A Specified Manufacturer, Submit The Following Required Item(s) for Approval Prior to Fabrication:
Finish Sample **Shop Drawing**

Manufacturer to confirm the Product meets Hilton Design and Construction Standards as noted in Section 2515.00

Instructions:

- All quantities to be verified by hotel operator prior to purchasing.
- It is the responsibility of the owner to interpret these specifications for each property.
- All interpretations of the specification MUST be submitted to Hilton Design Review (projecthub.hilton.com) for final approval prior to purchasing or implementation of any material.
- Must be of contract quality and suitable for commercial use.
- All materials and methods of construction must comply with all local fire and life safety codes and Brand Standards.
- Manufacturer to provide all necessary hardware for each item. All internal hardware (hinges, screws, bolts, etc.) shall be corrosion proof.
- Major joints as needed shall utilize lap joints or double doweled construction with corner blocks. Glue and staples are used to reinforce the joinery.
- Metal fasteners should be used where appropriate to ensure commercial frame strength.
- Manufacturer to verify all necessary parts, hardware and dimensions required for assembly.
- All wood to be kiln dried and treated to be insect and vermin free.
- Ensure that all pieces will fit in elevators and through doors prior to commencing fabrication.
- Show all pieces in shop drawings. Provide reproducible scaled shop drawings to Hotel Operator Representative prior to production.
- Provide clear alcohol and water-resistant penetrating sealer as required at wood.
- Solid hardwood frames to be certified sustainable sources. All stress joints to be connected by double doweled, screwed and glued corner reinforcement.



Project Name: Home2 Prototype FF&E Specifications
Scheme: B-Dynamic
Issue Date: March-23
Revisions: May-23 Δ1

Item Number: **(B) PA-309**
Item Name: Breakroom Dining Table @
Employee Breakroom
Area Name: Breakroom

- All corners of metal frame to be mitered; All welds to be filled and fully finished; Grind and smooth all edges; No visible welds, seams, or burn marks; Seal as required.
- Finish goods containing composite wood products must comply with California Code of Regulations 93120. Product and carton will be labeled in accordance with this regulation.
- Manufacturer to clearly mark each carton with item ID and specification number.

Project Name: Home2 Prototype FF&E Specifications
 Scheme: B-Dynamic
 Issue Date: March-23

Item Number: **(B) PA-310**
 Item Name: Towel Station at Fitness
 Area Name: Public Area - Fitness

Revisions:

Manufacturer:	Elkay Interior Systems	D'Style Inc
Address:	1 Mid America Plaza, Floor 3 Oakbrook Terrace, IL 60181	3451 Main Street, Suite 108 Chula Vista, CA 91911
Phone:	414-224-0957	619-662-0560 ext.136
Contact:	Courtney Messersmith	Eric Constantino
E-mail:	hospitalitybids@elkayinteriorsystems.com	dsquotes@dstyle.com.com
Web:	www.elkayinteriorsystems.com	www.dstyleinc.com

Description: Required Custom Towel Station to Accommodate
 Required Accessory Items: Laundry Basket

Dimensions: 72"W x 18"D x 64"H
 Finish: Plastic laminate, finish to match PL-01 Wilsonart 5th
 Ave Elm 7966K-12 Soft Grain Texture with Aeon
 Hardware: 10" diameter, satin stainless steel grommet,
 quantity: 2

Notes:

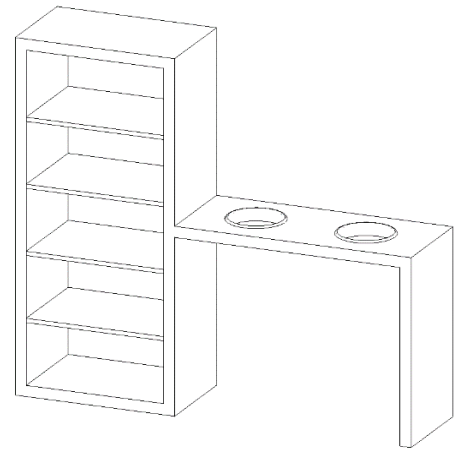

PL-01

Unless Using A Specified Manufacturer, Submit The Following Required Item(s) for Approval Prior to Fabrication:

Finish Sample **Shop Drawing**

Manufacturer to confirm the Product meets Hilton Design and Construction Standards as noted in Section 2515.00

Instructions:

- All quantities to be verified by hotel operator prior to purchasing.
- It is the responsibility of the owner to interpret these specifications for each property.
- All interpretations of the specification MUST be submitted to Hilton Design Review (projecthub.hilton.com) for final approval prior to purchasing or implementation of any material.
- Must be of contract quality and suitable for commercial use.
- All materials and methods of construction must comply with all local fire and life safety codes and Brand Standards.
- Manufacturer to provide all necessary hardware for each item. All internal hardware (hinges, screws, bolts, etc.) shall be corrosion proof.
- Major joints as needed shall utilize lap joints or double doweled construction with corner blocks. Glue and staples are used to reinforce the joinery.
- Metal fasteners should be used where appropriate to ensure commercial frame strength.
- Manufacturer to verify all necessary parts, hardware and dimensions required for assembly.



Project Name: Home2 Prototype FF&E Specifications
Scheme: B-Dynamic
Issue Date: March-23

Item Number: **(B) PA-310**
Item Name: Towel Station at Fitness
Area Name: Public Area - Fitness

Revisions:

- All wood to be kiln dried and treated to be insect and vermin free.
- Ensure that all pieces will fit in elevators and through doors prior to commencing fabrication.
- Show all pieces in shop drawings. Provide reproducible scaled shop drawings to Hotel Operator Representative prior to production.
- Provide clear alcohol and water-resistant penetrating sealer as required at wood.
- Solid hardwood frames to be certified sustainable sources. All stress joints to be connected by double doweled, screwed and glued corner reinforcement.
- All corners of metal frame to be mitered; All welds to be filled and fully finished; Grind and smooth all edges; No visible welds, seams, or burn marks; Seal as required.
- Finish goods containing composite wood products must comply with California Code of Regulations 93120. Product and carton will be labeled in accordance with this regulation.
- Manufacturer to clearly mark each carton with item ID and specification number.

Project Name: Home2 Prototype FF&E Specifications
 Scheme: B-Dynamic
 Issue Date: March-23

Item Number: **(B) PA-311**
 Item Name: Food Delivery Pick-Up Console
 Area Name: Public Area - Lobby

Revisions:

Manufacturer:	Elkay Interior Systems	D'Style Inc
Address:	1 Mid America Plaza, Floor 3 Oakbrook Terrace, IL 60181	3451 Main Street, Suite 108 Chula Vista, CA 91911
Phone:	414-224-0957	619-662-0560 ext.136
Contact:	Courtney Messersmith	Eric Constantino
E-mail:	hospitalitybids@elkayinteriorsystems.com	dsquotes@dstyle.com.com
Web:	www.elkayinteriorsystems.com	www.dstyleinc.com

Description: Food Delivery Pick-Up Console with Shelf and Slatted Side Panels

Width: 48"
 Depth: 20"
 Height: 42"
 Top Thickness: 2cm
 Edge Detail: Square with eased edge
 Top Material/Finish: Quartz top, Finish to match ST-01 Daltile One Quartz - Simply White Polished

Base Material/Finish: Plastic Laminate, Finish to match PL-02 Wilsonart High Line 7970K-18 Linearity Finish with Aeon on shelf, and back panel
 Sides - Plastic laminate to match PL-01 Wilsonart 5th Ave Elm 7966K-12 Soft Grain Texture with Aeon

Data/Electrical: NA

Notes: Provide heavy duty adjustable nylon glides.

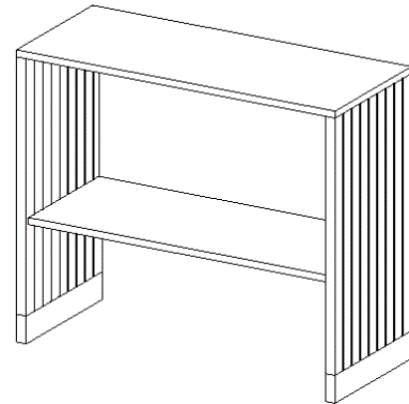

Unless Using A Specified Manufacturer, Submit The Following Required Item(s) for Approval Prior to Fabrication:

Finish Sample **Shop Drawing**

Manufacturer to confirm the Product meets Hilton Design and Construction Standards as noted in Section 2515.00

Instructions:

- All quantities to be verified by hotel operator prior to purchasing.
- It is the responsibility of the owner to interpret these specifications for each property.
- All interpretations of the specification MUST be submitted to Hilton Design Review (projecthub.hilton.com) for final approval prior to purchasing or implementation of any material.
- Must be of contract quality and suitable for commercial use.
- All materials and methods of construction must comply with all local fire and life safety codes and Brand Standards.
- Manufacturer to provide all necessary hardware for each item. All internal hardware (hinges, screws, bolts, etc.) shall be corrosion proof.



Project Name: Home2 Prototype FF&E Specifications
Scheme: B-Dynamic
Issue Date: March-23

Item Number: **(B) PA-311**
Item Name: Food Delivery Pick-Up Console
Area Name: Public Area - Lobby

Revisions:

- Major joints as needed shall utilize lap joints or double doweled construction with corner blocks. Glue and staples are used to reinforce the joinery.
- Metal fasteners should be used where appropriate to ensure commercial frame strength.
- Manufacturer to verify all necessary parts, hardware and dimensions required for assembly.
- All wood to be kiln dried and treated to be insect and vermin free.
- Ensure that all pieces will fit in elevators and through doors prior to commencing fabrication.
- Show all pieces in shop drawings. Provide reproducible scaled shop drawings to Hotel Operator Representative prior to production.
- Provide clear alcohol and water-resistant penetrating sealer as required at wood.
- Solid hardwood frames to be certified sustainable sources. All stress joints to be connected by double doweled, screwed and glued corner reinforcement.
- All corners of metal frame to be mitered; All welds to be filled and fully finished; Grind and smooth all edges; No visible welds, seams, or burn marks; Seal as required.
- Finish goods containing composite wood products must comply with California Code of Regulations 93120. Product and carton will be labeled in accordance with this regulation.
- Manufacturer to clearly mark each carton with item ID and specification number.

Project Name: Home2 Prototype FF&E Specifications
 Scheme: B-Dynamic

Item Number: **(B) PA-312**
 Item Name: Meeting Room Conference Table

Issue Date: March-23
 Revisions: May-23 Δ1

Area Name: Public Area - Meeting Room

Manufacturer:	Elkay Interior Systems	D'Style Inc
Address:	1 Mid America Plaza, Floor 3 Oakbrook Terrace, IL 60181	3451 Main Street, Suite 108 Chula Vista, CA 91911
Phone:	414-224-0957	619-662-0560 ext.136
Contact:	Courtney Messersmith	Eric Constantino
E-mail:	hospitalitybids@elkayinteriorsystems.com	dsquotes@dstyle.com.com
Web:	www.elkayinteriorsystems.com	www.dstyleinc..com

Description: Dual Pedestal Base Conference Table
 Width: 96"
 Depth: 42"
 Height: 30"
 Top Thickness: 1 1/8"
 Edge Detail: Reverse knife edge
 Top Material/Finish: Plastic laminate top, finish to match PL-01 Wilsonart 5th Ave Elm 7966K-12 Soft Grain Texture with Aeon, with clear coat edge
 Base Material/Finish: Square steel 3" column with 10" welded metal plate, finish to match TIGER Drylac Satin Jet Black 38/80020
 Data/Electrical: Include (2) EXP/MHO Power/Data Centers - Includes 2 simplex, 15 amp, 72" power cord standard with single side. Clear anodized aluminum. Centered in table top.
 Notes: Size of table top requires two (2) pedestal bases. Top to be attached to bases per manufacturer's recommendation.

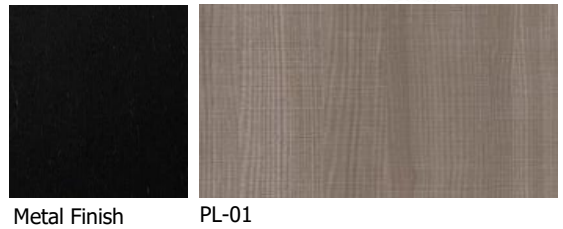
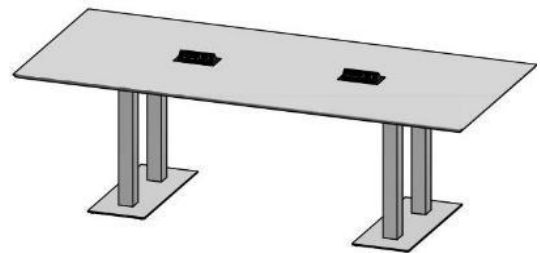

Unless Using A Specified Manufacturer, Submit The Following Required Item(s) for Approval Prior to Fabrication:

Finish Sample **Shop Drawing**

Manufacturer to confirm the Product meets Hilton Design and Construction Standards as noted in Section 2515.00

Instructions:

- All quantities to be verified by hotel operator prior to purchasing.
- It is the responsibility of the owner to interpret these specifications for each property.
- All interpretations of the specification MUST be submitted to Hilton Design Review (projecthub.hilton.com) for final approval prior to purchasing or implementation of any material.
- Must be of contract quality and suitable for commercial use.
- All materials and methods of construction must comply with all local fire and life safety codes and Brand Standards.
- Manufacturer to provide all necessary hardware for each item. All internal hardware (hinges, screws, bolts, etc.) shall be corrosion proof.
- Major joints as needed shall utilize lap joints or double doweled construction with corner blocks. Glue and staples are used to reinforce the joinery.
- Metal fasteners should be used where appropriate to ensure commercial frame strength.
- Manufacturer to verify all necessary parts, hardware and dimensions required for assembly.



Project Name: Home2 Prototype FF&E Specifications
Scheme: B-Dynamic

Item Number: **(B) PA-312**
Item Name: Meeting Room Conference Table

Issue Date: March-23

Area Name: Public Area - Meeting Room

Revisions: May-23 Δ1

- All wood to be kiln dried and treated to be insect and vermin free.
- Ensure that all pieces will fit in elevators and through doors prior to commencing fabrication.
- Show all pieces in shop drawings. Provide reproducible scaled shop drawings to Hotel Operator Representative prior to production.
- Provide clear alcohol and water-resistant penetrating sealer as required at wood.
- Solid hardwood frames to be certified sustainable sources. All stress joints to be connected by double doweled, screwed and glued corner reinforcement.
- All corners of metal frame to be mitered; All welds to be filled and fully finished; Grind and smooth all edges; No visible welds, seams, or burn marks; Seal as required.
- Finish goods containing composite wood products must comply with California Code of Regulations 93120. Product and carton will be labeled in accordance with this regulation.
- Manufacturer to clearly mark each carton with item ID and specification number.

Project Name: Home2 Prototype FF&E Specifications
 Scheme: B-Dynamic
 Issue Date: March-23
 Revisions: June-23 Δ2

Item Number: **(B) PA-313**
 Item Name: Meeting Room Training Table
 Area Name: Public Area - Meeting Room

Manufacturer:	MTS Seating	Shelby Williams
Address:	7100 Industrial Drive Temperance, MI 481182	810 West Highway 25/70 Newport, TN 37821
Phone:	734-847-3875	800-873-3252
Contact:	Lisa McAfee	Jordan McInturf
E-mail:	lisamcafee@mtsseating.com	jmcinturf@mycgroup.com.com
Web:	www.mtsseating.com	www.shelbywilliams.com

Description: Meeting Room Folding Training Table with Modesty Panel
 Model: Folding Table at Meeting Room
 Dimensions: Top: 72" W x 24" D x 1-1/4" H
 Legs: 1-1/2" Sq. Tube x 29-3/4" H
 Edge Detail: Black vinyl bumper edge
 Top Material/Finish: Plastic laminate top, finish to match PL-01 Wilsonart 5th Ave Elm 7966K-12 Soft Grain Texture with Aeon
 Base Material/Finish: Leg: To match TIGER Drylac Satin Jet Black 38/80020, pin style leg brace with locking mechanism
 Notes: Provide heavy duty adjustable nylon glides.



Metal Finish



PL-01

Unless Using A Specified Manufacturer, Submit The Following Required Item(s) for Approval Prior to Fabrication:

Finish Sample **Shop Drawing**

Manufacturer to confirm the Product meets Hilton Design and Construction Standards as noted in Section 2515.00

Instructions:

- All quantities to be verified by hotel operator prior to purchasing.
- It is the responsibility of the owner to interpret these specifications for each property.
- All interpretations of the specification MUST be submitted to Hilton Design Review (projecthub.hilton.com) for final approval prior to purchasing or implementation of any material.
- Must be of contract quality and suitable for commercial use.
- All materials and methods of construction must comply with all local fire and life safety codes and Brand Standards.
- Manufacturer to provide all necessary hardware for each item. All internal hardware (hinges, screws, bolts, etc.) shall be corrosion proof.
- Major joints as needed shall utilize lap joints or double doweled construction with corner blocks. Glue and staples are used to reinforce the joinery.
- Metal fasteners should be used where appropriate to ensure commercial frame strength.
- Manufacturer to verify all necessary parts, hardware and dimensions required for assembly.
- All wood to be kiln dried and treated to be insect and vermin free.
- Ensure that all pieces will fit in elevators and through doors prior to commencing fabrication.



Project Name: Home2 Prototype FF&E Specifications
Scheme: B-Dynamic
Issue Date: March-23
Revisions: June-23 Δ2

Item Number: **(B) PA-313**
Item Name: Meeting Room Training Table
Area Name: Public Area - Meeting Room

-
- Show all pieces in shop drawings. Provide reproducible scaled shop drawings to Hotel Operator Representative prior to production.
 - Provide clear alcohol and water-resistant penetrating sealer as required at wood.
 - Solid hardwood frames to be certified sustainable sources. All stress joints to be connected by double doweled, screwed and glued corner reinforcement.
 - All corners of metal frame to be mitered; All welds to be filled and fully finished; Grind and smooth all edges; No visible welds, seams, or burn marks; Seal as required.
 - Finish goods containing composite wood products must comply with California Code of Regulations 93120. Product and carton will be labeled in accordance with this regulation.
 - Manufacturer to clearly mark each carton with item ID and specification number.

Project Name: Home2 Prototype FF&E Specifications Item Number: **(B) PA-314**
 Scheme: B-Dynamic Item Name: Retail Table - Large (Market Table)
 Issue Date: March-23 Area Name: Public Area - Market
 Revisions: June-23 Δ2

Manufacturer:	Elkay Interior Systems	D'Style Inc
Address:	1 Mid America Plaza, Floor 3 Oakbrook Terrace, IL 60181	3451 Main Street, Suite 108 Chula Vista, CA 91911
Phone:	414-224-0957	619-662-0560 ext.136
Contact:	Courtney Messersmith	Eric Constantino
E-mail:	hospitalitybids@elkayinteriorsystems.com	dsquotes@dstyle.com.com
Web:	www.elkayinteriorsystems.com	www.dstyleinc.com

Description: Mobile Market Display Table - Large, with Two Lower Shelves
 Width: 52"
 Depth: 24"
 Height: 36"
 Top Thickness: 2cm
 Edge Detail: Straight with eased edge
 Top Material/Finish: Quartz top, Finish to match ST-01 Daltile One Quartz - Simply White Polished
 Base Material/Finish: Lower Shelves & Toe Kick: Plastic laminate, Finish to match PL-01 Wilsonart 5th Ave Elm 7966K-12 Soft Grain Texture with Aeon
 Supports: Metal powder-coated to match TIGER Drylac Satin Jet Black 38/80020

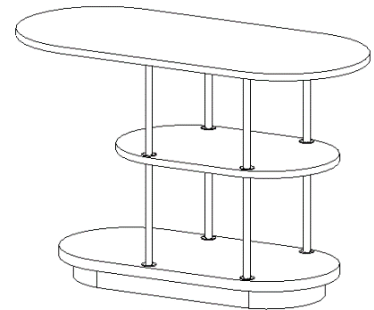

Data/Electrical: NA
 Notes:



Unless Using A Specified Manufacturer, Submit The Following Required Item(s) for Approval Prior to Fabrication:
Finish Sample **Shop Drawing**

Manufacturer to confirm the Product meets Hilton Design and Construction Standards as noted in Section 2515.00

Instructions:

- All quantities to be verified by hotel operator prior to purchasing.
- It is the responsibility of the owner to interpret these specifications for each property.
- All interpretations of the specification MUST be submitted to Hilton Design Review (projecthub.hilton.com) for final approval prior to purchasing or implementation of any material.
- Must be of contract quality and suitable for commercial use.
- All materials and methods of construction must comply with all local fire and life safety codes and Brand Standards.
- Manufacturer to provide all necessary hardware for each item. All internal hardware (hinges, screws, bolts, etc.) shall be corrosion proof.
- Major joints as needed shall utilize lap joints or double doweled construction with corner blocks. Glue and staples are used to reinforce the joinery.
- Metal fasteners should be used where appropriate to ensure commercial frame strength.



Project Name: Home2 Prototype FF&E Specifications
Scheme: B-Dynamic
Issue Date: March-23
Revisions: June-23 Δ2

Item Number: **(B) PA-314**
Item Name: Retail Table - Large (Market Table)
Area Name: Public Area - Market

- Manufacturer to verify all necessary parts, hardware and dimensions required for assembly.
- All wood to be kiln dried and treated to be insect and vermin free.
- Ensure that all pieces will fit in elevators and through doors prior to commencing fabrication.
- Show all pieces in shop drawings. Provide reproducible scaled shop drawings to Hotel Operator Representative prior to production.
- Provide clear alcohol and water-resistant penetrating sealer as required at wood.
- Solid hardwood frames to be certified sustainable sources. All stress joints to be connected by double doweled, screwed and glued corner reinforcement.
- All corners of metal frame to be mitered; All welds to be filled and fully finished; Grind and smooth all edges; No visible welds, seams, or burn marks; Seal as required.
- Finish goods containing composite wood products must comply with California Code of Regulations 93120. Product and carton will be labeled in accordance with this regulation.
- Manufacturer to clearly mark each carton with item ID and specification number.

Project Name: Home2 Prototype FF&E Specifications Item Number: **(B) PA-315**
 Scheme: B-Dynamic Item Name: Retail Table - Small (Market Table)
 Issue Date: March-23
 Revisions: June-23 Δ2 Area Name: Public Area - Market

Manufacturer: **Elkay Interior Systems** **D'Style Inc**
 Address: 1 Mid America Plaza, Floor 3 3451 Main Street, Suite 108
 Oakbrook Terrace, IL 60181 Chula Vista, CA 91911
 Phone: 414-224-0957 619-662-0560 ext.136
 Contact: Courtney Messersmith Eric Constantino
 E-mail: hospitalitybids@elkayinteriorsystems.com dsquotes@dstyle.com.com
 Web: www.elkayinteriorsystems.com www.dstyleinc.com

Description: Mobile Market Display Table - Small, with Two Lower Shelves
 Width: 34" Dia.
 Depth: 34" Dia.
 Height: 31"
 Top Thickness: 2cm
 Edge Detail: Straight with eased edge
 Top Material/Finish: Quartz top, Finish to match ST-01 Daltile One Quartz - Simply White Polished
 Base Material/Finish: Lower Shelves & Toe Kick: Plastic Laminate, Finish to match PL-01 Wilsonart 5th Ave Elm 7966K-12 Soft Grain Texture with Aeon
 Supports: Metal powder-coated to match TIGER Drylac Satin Jet Black 38/80020

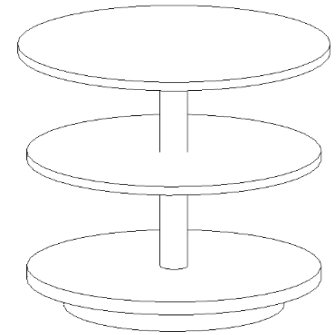

Data/Electrical: NA
 Notes:

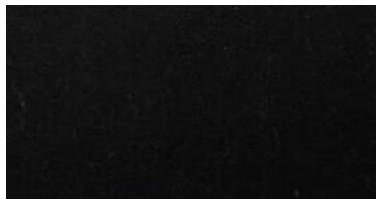

Metal Finish



PL-01



ST-01

Unless Using A Specified Manufacturer, Submit The Following Required Item(s) for Approval Prior to Fabrication:

Finish Sample **Shop Drawing**

Manufacturer to confirm the Product meets Hilton Design and Construction Standards as noted in Section 2515.00

Instructions:

- All quantities to be verified by hotel operator prior to purchasing.
- It is the responsibility of the owner to interpret these specifications for each property.
- All interpretations of the specification MUST be submitted to Hilton Design Review (projecthub.hilton.com) for final approval prior to purchasing or implementation of any material.
- Must be of contract quality and suitable for commercial use.
- All materials and methods of construction must comply with all local fire and life safety codes and Brand Standards.
- Manufacturer to provide all necessary hardware for each item. All internal hardware (hinges, screws, bolts, etc.) shall be corrosion proof.
- Major joints as needed shall utilize lap joints or double doweled construction with corner blocks. Glue and staples are used to reinforce the joinery.
- Metal fasteners should be used where appropriate to ensure commercial frame strength.



Project Name:	Home2 Prototype FF&E Specifications	Item Number:	(B) PA-315
Scheme:	B-Dynamic	Item Name:	Retail Table - Small (Market Table)
Issue Date:	March-23		
Revisions:	June-23 Δ2	Area Name:	Public Area - Market

- Manufacturer to verify all necessary parts, hardware and dimensions required for assembly.
- All wood to be kiln dried and treated to be insect and vermin free.
- Ensure that all pieces will fit in elevators and through doors prior to commencing fabrication.
- Show all pieces in shop drawings. Provide reproducible scaled shop drawings to Hotel Operator Representative prior to production.
- Provide clear alcohol and water-resistant penetrating sealer as required at wood.
- Solid hardwood frames to be certified sustainable sources. All stress joints to be connected by double doweled, screwed and glued corner reinforcement.
- All corners of metal frame to be mitered; All welds to be filled and fully finished; Grind and smooth all edges; No visible welds, seams, or burn marks; Seal as required.
- Finish goods containing composite wood products must comply with California Code of Regulations 93120. Product and carton will be labeled in accordance with this regulation.
- Manufacturer to clearly mark each carton with item ID and specification number.

Project Name: Home2 Prototype FF&E Specifications
 Scheme: B-Dynamic
 Issue Date: March-23
 Revisions: June-23 Δ2

Item Number: **(B) PA-316**
 Item Name: Retail Display System
 Area Name: Public Area - Market

Manufacturer: **Opto Systems**
 Address: 1325 N. Mittel Boulevard
 Wood Dale, IL 60191
 Phone: 847-541-6786 x5799
 Contact: Nicole Schopp
 E-mail: nschopp@optosystem.com
 Web: www.optosystem.com

Description: Retail Display System @ Market
 Style: Retail display with shelves, hooks, angle baskets, locking storage drawers, and LED lighting
 Dimensions: 96"W x 19"D x 84"H, see drawings for individual components' dimensions
 Material/Finish: Main casework: Plastic Laminate, to match PL-02 Wilsonart High Line 7970K-18 Linearity Finish with Aeon. Metal powder coat, match RAL 9004 Signal Black. Rail and hooks, Satin Nickel
 Notes: Manufacturer to verify size requirements by on-site measurements taken prior to fabrication. Units must be adjustable in field for overall height and shelf locations.
 All pieces to be mechanically secured together. Provide all corrosion proof hardware to secure pieces together.
 All cabinets to have same keyed locks.
 Shelves to have undermount LED lights.

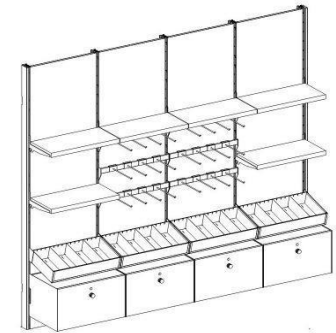

PL-02



Metal Finish

Unless Using A Specified Manufacturer, Submit The Following Required Item(s) for Approval Prior to Fabrication:

Finish Sample **Shop Drawing**

Manufacturer to confirm the Product meets Hilton Design and Construction Standards as noted in Section 2515.00

Instructions:

- All quantities to be verified by hotel operator prior to purchasing.
- It is the responsibility of the owner to interpret these specifications for each property.
- All interpretations of the specification MUST be submitted to Hilton Design Review (projecthub.hilton.com) for final approval prior to purchasing or implementation of any material.
- Must be of contract quality and suitable for commercial use.
- All materials and methods of construction must comply with all local fire and life safety codes and Brand Standards.
- Manufacturer to provide all necessary hardware for each item. All internal hardware (hinges, screws, bolts, etc.) shall be corrosion proof.



Project Name: Home2 Prototype FF&E Specifications
Scheme: B-Dynamic
Issue Date: March-23
Revisions: June-23 Δ2

Item Number: **(B) PA-316**
Item Name: Retail Display System
Area Name: Public Area - Market

-
- Major joints as needed shall utilize lap joints or double doweled construction with corner blocks. Glue and staples are used to reinforce the joinery.
 - Metal fasteners should be used where appropriate to ensure commercial frame strength.
 - Manufacturer to verify all necessary parts, hardware and dimensions required for assembly.
 - All wood to be kiln dried and treated to be insect and vermin free.
 - Ensure that all pieces will fit in elevators and through doors prior to commencing fabrication.
 - Show all pieces in shop drawings. Provide reproducible scaled shop drawings to Hotel Operator Representative prior to production.
 - Provide clear alcohol and water-resistant penetrating sealer as required at wood.
 - Solid hardwood frames to be certified sustainable sources. All stress joints to be connected by double doweled, screwed and glued corner reinforcement.
 - All corners of metal frame to be mitered; All welds to be filled and fully finished; Grind and smooth all edges; No visible welds, seams, or burn marks; Seal as required.
 - Finish goods containing composite wood products must comply with California Code of Regulations 93120. Product and carton will be labeled in accordance with this regulation.
 - Manufacturer to clearly mark each carton with item ID and specification number.

Project Name: Home2 Prototype FF&E Specifications Item Number: **(B) PA-400**
 Scheme: B-Dynamic Item Name: Roller Shade @ Lobby & Fitness Room (Curtain Wall)
 Issue Date: March-23
 Revisions: June-23 Δ2 Area Name: Public Area- Lobby & Fitness Room

Manufacturer:	EE Sewing	Fabtex	Hunter Douglas Hospitality	Standard Textile
Address:	21601 E 340 Road Chelsea, Oklahoma 74016	29 Woodbine Lane Danville, PA 17821	12975 Brookprinter Place, Ste 210 Poway, CA 92064	One Knollcrest Dr Cincinnati, Ohio 45237
Phone:	918-789-5881	800-778-2791 x738	571-239-2746	410-484-5836
Contact:	Luke Cowles	Eric Frantz	Lindsey Malone	Jerry Katz
E-mail:	ee@junct.com	eric.frantz@fabtex.com	lindsey@icfgroup.net	jkatz@standardtextile.com
Web:	www.eesewing.com	www.fabtex.com	www.hunterdouglas.com	www.standardtextile.com

Description: Manual Control Sheer Roller Shade at Fitness Room
 Ceiling Height: Lobby 8'-10"H VIF, Fitness: 9'-3"H VIF
 Opening Size: Lobby: Approx. 15'W x approx. 6'H stop at top of Perch Table
 Fitness Room: Approx. 19'W x approx. 8'H. All dimensions to be VIF.
 Mounting Method: Outside mount to ceiling above window
 Hardware: Right Hand Operable Chain, Single/ Manual Clutch System
 Panels Style: Sheer Shade: FR roller shade with fabric wrapped hem bar
 Control Type: Bead chain (stainless steel)- Chains to be secured to wall below with hold down brackets- Must comply with ANSI standard for child safety (ANSI WCMA A100.1 Section 6.5) Designer to determine left and right orientation per plan locations.



Hunter Douglas Sheer

COM/COL: Fabric @ Sheer:
 Hunter Douglas; Pattern: Bleecker; Color: Steel; Content: 100% Polyester;
 Width: 118"; Openness: 6%; Fire Rating: NFPA 701-10TM#1
 EE Sewing, Inc.: Pattern: Stratos; Color: Harbor
 Standard Textile; Pattern: Maui; Color: Lava Rock; Content: 100% Polyester;
 Width: 110"; Openness: <1%; Repeat: 1"V, 1"H; Fire Rating: NFPA 701

Components: Clutch Hardware: RB-500
 Notes: Manufacturer to verify all opening sizes and fabric requirements prior to fabrication.

Unless Using A Specified Manufacturer, Submit The Following Required Item(s) for Approval Prior to Fabrication:
Cutting **Shop Drawing** **Flame Certificate** **Finish Sample**

Manufacturer to confirm the Product meets Hilton Design and Construction Standards as noted in Section 2515.03

Instructions:

- All quantities to be verified by hotel operator prior to purchasing.
- It is the responsibility of the owner to interpret these specifications for each property.
- All interpretations of the specification MUST be submitted to Hilton Design Review (projecthub.hilton.com) for final approval prior to purchasing or implementation of any material.
- Must be of contract quality and suitable for commercial use.
- COM quantities must be verified by fabricator prior to ordering.
- All materials and methods of construction must comply with all local fire and life safety codes for use in hotels and other public spaces, and Brand Standards.
- All quantity requirements must be verified by on-site measurements taken prior to fabrication.
- Drapery fabricator to provide all hardware complete for installation.
- Drapery fabricator is responsible for the size and quantity of all hardware to be used.
- Draperies must meet Class 1 ASTM E-84 and NFPA 701 Small and Large Scale as required by local and state fire codes for use in hotels.
- Manufacturer to clearly mark each carton with item ID and specification number.



Project Name:	Home2 Prototype FF&E Specifications	Item Number:	(B) PA-400
Scheme:	B-Dynamic	Item Name:	Roller Shade @ Lobby & Fitness Room (Curtain Wall)
Issue Date:	March-23	Area Name:	Public Area- Lobby & Fitness Room
Revisions:	June-23 Δ2		

- Sheer treatments must have a 1" single side hem, 4" single heading and 4" double bottom hem. Blackout treatments must have a 1" single side hem, 4" single heading and 1/2" double bottom hem.
- Sheer and blackout must have 1/2" clear front mounted baton that is 48" AFF.
- All window treatments to have 4" overlap in center when they are two-way draw.

Project Name: Home2 Prototype FF&E Specifications Item Number: **(B) PA-401**
 Scheme: B-Dynamic Item Name: Roller Shade @ Fitness Room (Framed Windows) & Breakroom
 Issue Date: March-23
 Revisions: June-23 Δ2 Area Name: Public Area - Fitness Room

Manufacturer:	EE Sewing	Fabtex	Hunter Douglas Hospitality	Standard Textile
Address:	21601 E 340 Road Chelsea, Oklahoma 74016	29 Woodbine Lane Danville, PA 17821	12975 Brookprinter Place, Ste 210 Poway, CA 92064	One Knollcrest Dr Cincinnati, Ohio 45237
Phone:	918-789-5881	800-778-2791 x738	571-239-2746	410-484-5836
Contact:	Luke Cowles	Eric Frantz	Lindsey Malone	Jerry Katz
E-mail:	ee@junct.com	eric.frantz@fabtex.com	lindsey@icfgroup.net	jkatz@standardtextile.com
Web:	www.eesewing.com	www.fabtex.com	www.hunterdouglas.com	www.standardtextile.com

Description: Manual Control Sheer Roller Shade at Fitness Framed Windows and Breakroom Windows

Ceiling Height: Fitness: 9'-3"H VIF, Breakroom: 8'-0"H VIF
 Opening Size: Fitness: 6'-0"W x 6'-8"H VIF, Breakroom: 6'-0"W x 6'-8"H VIF

Mounting Method: Outside mount to ceiling above window
 Hardware: Right Hand Operable Chain, Single/ Manual Clutch System
 Panels Style: Sheer Shade: FR roller shade with fabric wrapped hem bar
 Control Type: Bead chain (stainless steel)- Chains to be secured to wall below with hold down brackets- Must comply with ANSI standard for child safety (ANSI WCMA A100.1 Section 6.5) Designer to determine left and right orientation per plan locations.

COM/COL: Fabric @ Sheer:

Hunter Douglas; Pattern: Bleecker; Color: Steel; Content: 100% Polyester;
 Width: 118"; Openness: 6%; Fire Rating: NFPA 701-10TM#1
 EE Sewing, Inc.: Pattern: Stratos; Color: Harbor
 Standard Textile; Pattern: Maui; Color: Lava Rock; Content: 100% Polyester;
 Width: 110"; Openness: <1%; Repeat: 1"V, 1"H; Fire Rating: NFPA 701

Components: Fascia: 4" Aluminum
 Color: Black
 Length: Coordinate with shade width's above (VIF)
 Clutch Hardware: RB-500

Notes: Manufacturer to verify all opening sizes and fabric requirements prior to fabrication.
 Manufacturers to provide fascia to cove roll (fascia finish to match meal window frame).

Unless Using A Specified Manufacturer, Submit The Following Required Item(s) for Approval Prior to Fabrication:

Cutting **Shop Drawing** **Flame Certificate** **Finish Sample**

Manufacturer to confirm the Product meets Hilton Design and Construction Standards as noted in Section 2515.03

Instructions:

- All quantities to be verified by hotel operator prior to purchasing.
- It is the responsibility of the owner to interpret these specifications for each property.
- All interpretations of the specification MUST be submitted to Hilton Design Review (projecthub.hilton.com) for final approval prior to purchasing or implementation of any material.
- Must be of contract quality and suitable for commercial use.
- COM quantities must be verified by fabricator prior to ordering.
- All materials and methods of construction must comply with all local fire and life safety codes for use in hotels and other public spaces, and Brand Standards.
- All quantity requirements must be verified by on-site measurements taken prior to fabrication.
- Drapery fabricator to provide all hardware complete for installation.



Hunter Douglas Sheer



Project Name:	Home2 Prototype FF&E Specifications	Item Number:	(B) PA-401
Scheme:	B-Dynamic	Item Name:	Roller Shade @ Fitness Room (Framed Windows) & Breakroom
Issue Date:	March-23	Area Name:	Public Area - Fitness Room
Revisions:	June-23 Δ2		

- Drapery fabricator is responsible for the size and quantity of all hardware to be used.
- Draperies must meet Class 1 ASTM E-84 and NFPA 701 Small and Large Scale as required by local and state fire codes for use in hotels.
- Manufacturer to clearly mark each carton with item ID and specification number.
- Sheer treatments must have a 1" single side hem, 4" single heading and 4" double bottom hem. Blackout treatments must have a 1" single side hem, 4" single heading and 1/2" double bottom hem.
- Sheer and blackout must have 1/2" clear front mounted baton that is 48" AFF.

Project Name: Home2 Prototype FF&E Specifications Item Number: **(B) PA-402**
 Scheme: B-Dynamic Item Name: Roller Shade @ Sales, Boardroom & Meeting Room
 Issue Date: March-23
 Revisions: June-23 Δ2 Area Name: Public Areas - Boardroom & Meeting Room; Back of House - Sales

Manufacturer:	EE Sewing	Fabtex	Hunter Douglas Hospitality	Standard Textile
Address:	21601 E 340 Road Chelsea, Oklahoma 74016	29 Woodbine Lane Danville, PA 17821	12975 Brookprinter Place, Ste 210 Poway, CA 92064	One Knollcrest Dr Cincinnati, Ohio 45237
Phone:	918-789-5881	800-778-2791 x738	571-239-2746	410-484-5836
Contact:	Luke Cowles	Eric Frantz	Lindsey Malone	Jerry Katz
E-mail:	ee@junct.com	eric.frantz@fabtex.com	lindsey@jcfgroup.net	jkatz@standardtextile.com
Web:	www.eesewing.com	www.fabtex.com	www.hunterdouglas.com	www.standardtextile.com

Description: Manual Control Sheer Roller Shade at Sales
 Ceiling Height: 9'-3" VIF
 Opening Size: 6'-0"W x 6'-8"H VIF
 Mounting Method: Outside mount to ceiling above window
 Hardware: Right Hand Operable Chain, Single/ Manual Clutch System
 Panels Style: Sheer Shade: FR roller shade with fabric wrapped hem bar
 Panels Style: Blackout Roller Shade: FR roller shade with fabric wrapped hem bar
 Control Type: Bead chain (stainless steel)- Chains to be secured to wall below with hold down brackets- Must comply with ANSI standard for child safety (ANSI WCMA A100.1 Section 6.5) Designer to determine left and right orientation per plan locations.



Hunter Douglas Blackout



Fabtex Blackout

Blackout COM/COL: Hunter Douglas Roller Blackout Fabric
 Pattern: Striate
 Color: Mist (0% openness)
 Fire Rating: NFPA 701-10 TM#1, CA US Title 19, ASTM E2180, ASTM G21
 Content: 100% Polyester with Acrylic Coating (PVC Free)
 Width: 110"
 Repeat: NA
 Railroad: No

Fabtex: Pattern: Pixley BO, Color: Light Gray
 EE Sewing: Pattern: Linen, Color: 07 BO

Sheer COM/COL: Hunter Douglas; Pattern: Bleecker; Color: White; Content: 100% Polyester;
 Width: 118"; Openness: 6%; Fire Rating: NFPA 701-10TM#1
 EE Sewing, Inc.: Pattern: Stratos; Color: White
 Standard Textile; Pattern: Maui; Color: Lava Rock; Content: 100% Polyester;
 Width: 110"; Openness: <1%; Repeat: 1"V, 1"H; Fire Rating: NFPA 701

Fabtex: Pattern: Pugba; Color: White

Components: Fascia: 4" Aluminum
 Color: Black
 Length: Coordinate with shade width's above (VIF)
 Clutch Hardware: RB-500



Hunter Douglas Sheer

Notes: Manufacturer to verify all opening sizes and fabric requirements prior to fabrication.
 Manufacturers to provide fascia to cove roll (fascia finish to match meal window frame).

Unless Using A Specified Manufacturer, Submit The Following Required Item(s) for Approval Prior to Fabrication:
Cutting **Shop Drawing** **Flame Certificate** **Finish Sample**

Manufacturer to confirm the Product meets Hilton Design and Construction Standards as noted in Section 2515.03

Instructions:



Project Name:	Home2 Prototype FF&E Specifications	Item Number:	(B) PA-402
Scheme:	B-Dynamic	Item Name:	Roller Shade @ Sales, Boardroom & Meeting Room
Issue Date:	March-23	Area Name:	Public Areas - Boardroom & Meeting Room; Back of House - Sales
Revisions:	June-23 Δ2		

- All quantities to be verified by hotel operator prior to purchasing.
- It is the responsibility of the owner to interpret these specifications for each property.
- All interpretations of the specification MUST be submitted to Hilton Design Review (projecthub.hilton.com) for final approval prior to purchasing or implementation of any material.
- Must be of contract quality and suitable for commercial use.
- COM quantities must be verified by fabricator prior to ordering.
- All materials and methods of construction must comply with all local fire and life safety codes for use in hotels and other public spaces, and Brand Standards.
- All quantity requirements must be verified by on-site measurements taken prior to fabrication.
- Drapery fabricator to provide all hardware complete for installation.
- Drapery fabricator is responsible for the size and quantity of all hardware to be used.
- Draperies must meet Class 1 ASTM E-84 and NFPA 701 Small and Large Scale as required by local and state fire codes for use in hotels.
- Manufacturer to clearly mark each carton with item ID and specification number.
- Sheer treatments must have a 1" single side hem, 4" single heading and 4" double bottom hem. Blackout treatments must have a 1" single side hem, 4" single heading and 1/2" double bottom hem.
- Sheer and blackout must have 1/2" clear front mounted baton that is 48" AFF.



Project Name: Home2 Prototype FF&E Specifications
 Scheme: B-Dynamic
 Issue Date: March-23
 Revisions: June-23 Δ2

Item Number: **(B) PA-500**
 Item Name: TV Lounge Artwork
 Area Name: Public Area - TV Lounge

Manufacturer:	Kalisher	PI Fine Art	Wendover Art Group
Address:	800 Taylor Street, Suite 9A-154 Durham, NC 27701	1180 Caledonia Road Toronto, Ontario M6A 2W5	6465 126th Ave N Largo, Florida 33773
Phone:	919-967-4300 x123	416-789-7156 x255	727-573-1417
Contact:	Claire Sugg	Elise Vandebosch	Carmine Giso
E-mail:	c.sugg@kalisher.com	hilton@pifineart.com	hilton@wendoverart.com
Web:	www.kalisher.com	www.pifineart.com	www.wendoverart.com

Description: Framed Print @ TV Lounge
 Dimensions: 48"W x 32" H
 Molding Number: Michelangelo 41-29
 Molding Width: 1 1/4"W x 1 1/8"H
 Finish: Michelangelo Avant-Garde 41-29
 Orientation: Vertical
 Mounting Height: See architectural drawings
 Hardware: 3 Point Security Hardware
 Notes: See Design Guide for artwork content requirements.



Unless Using A Specified Manufacturer, Submit The Following Required Item(s) for Approval Prior to Fabrication:
Finish Sample **Shop Drawing**

Manufacturer to confirm the Product meets Hilton Design and Construction Standards as noted in Section 2515.05

Instructions:

- All quantities to be verified by hotel operator prior to purchasing.
- It is the responsibility of the owner to interpret these specifications for each property.
- All interpretations of the specification MUST be submitted to Hilton Design Review (projecthub.hilton.com) for final approval prior to purchasing or implementation of any material.
- Must be of contract quality and suitable for commercial use.
- All materials and methods of construction must comply with all local fire and life safety codes for use in hotels and other public spaces, and Brand Standards.
- Manufacturer to provide all component parts for complete assembly and installation.
- Mounting method to be sufficient for weight of piece.
- All pieces must be crated for shipping. All corners should be wrapped with corner guards. Crates should be labeled with instructions for shipment, storage and opening of crate.
- Manufacturer to provide 3-point or continuous cleat security cleating system appropriate for the size and weight of the artwork.
- Manufacturer to clearly mark each carton with item ID and specification number.
- Provide 1/4" (6mm) backer sheet, gator foam or tempered Masonite.
- Wood frames to be certified sustainable sources. All stress joints to be connected by double doweled, screwed and glued corner reinforcement.
- Must adhere to CARB Title 17 Standards: formaldehyde emissions for hardwood plywood, particleboard, and medium density fiberboard may not exceed .05ppm.



Project Name: Home2 Prototype FF&E Specifications
Scheme: B-Dynamic
Issue Date: March-23
Revisions: June-23 Δ2

Item Number: **(B) PA-500**
Item Name: TV Lounge Artwork
Area Name: Public Area - TV Lounge

-
- Finish goods containing composite wood products must comply with California Code of Regulations 93120. Product and carton will be labeled in accordance with this regulation.

Project Name: Home2 Prototype FF&E Specifications Item Number: **(B) PA-501**
 Scheme: B-Dynamic Item Name: Decorative Mirror @ Guest Elevator Lobbies
 Issue Date: March-23
 Revisions: May-23 Δ1 Area Name: Public Area - Guest Elevator Lobbies

Manufacturer:	Majestic Mirror	PI Fine Art	Wendover Art Group
Address:	7425 N.W. 79th Street Miami, FL 33166	1180 Caledonia Road Toronto, Ontario M6A 2W5	6465 126th Ave N Largo, Florida 33773
Phone:	305-827-2661 x106	416-789-7156 x255	727-573-1417
Contact:	Adam Jaffe	Elise Vandebosch	Carmine Giso
E-mail:	adam@majesticmirror.com	hilton@pifineart.com	hilton@wendoverart.com
Web:	www.kalisher.com	www.pifineart.com	www.wendoverart.com

Description: Decorative Framed Mirror with Floor Level Number
 Dimensions: 30"W x 42" H
 Finish: Frame: Michelangelo Avant-Garde 41-29
 Mirror: Floor number to be film/vinyl to match Pantone 383C at bottom left corner of mirror 20"H x 18" W
 Molding Number: Michelangelo 41-29
 Molding Width: 1 1/4"W x 1 1/8"H
 Orientation: Vertical
 Mounting Height: See architectural drawings
 Hardware: 3 Point Security Hardware
 Notes: Font Type: Din Bold



Unless Using A Specified Manufacturer, Submit The Following Required Item(s) for Approval Prior to Fabrication:

Finish Sample **Shop Drawing**

Manufacturer to confirm the Product meets Hilton Design and Construction Standards as noted in Section 2515.06

Instructions:

- All quantities to be verified by hotel operator prior to purchasing.
- It is the responsibility of the owner to interpret these specifications for each property.
- All interpretations of the specification MUST be submitted to Hilton Design Review (projecthub.hilton.com) for final approval prior to purchasing or implementation of any material.
- Must be of contract quality and suitable for commercial use.
- All materials and methods of construction must comply with all local fire and life safety codes for use in hotels and other public spaces, and Brand Standards.
- Manufacturer to provide all component parts for complete assembly and installation.



Project Name:	Home2 Prototype FF&E Specifications	Item Number:	(B) PA-501
Scheme:	B-Dynamic	Item Name:	Decorative Mirror @ Guest Elevator Lobbies
Issue Date:	March-23	Area Name:	Public Area - Guest Elevator Lobbies
Revisions:	May-23 Δ1		

- Mounting method to be sufficient for weight of piece.
- All pieces must be crated for shipping. All corners should be wrapped with corner guards. Crates should be labeled with instructions for shipment, storage and opening of crate.
- For mirrors over 48" (1200mm) in any direction, provide inner frame and cross bracing.
- Manufacturer to provide 3-point or continuous cleat security cleating system appropriate for the size and weight of the mirror.

- Manufacturer to clearly mark each carton with item ID and specification number.
- Provide ¼" (6mm) backer sheet, gator foam or tempered Masonite.
- Wood frames to be certified sustainable sources. All stress joints to be connected by double doweled, screwed and glued corner reinforcement.
- Must adhere to CARB Title 17 Standards: formaldehyde emissions for hardwood plywood, particleboard, and medium density fiberboard may not exceed .05ppm.
- Finish goods containing composite wood products must comply with California Code of Regulations 93120. Product and carton will be labeled in accordance with this regulation.

Project Name: Home2 FF&E Specs
 Scheme: (B) Dynamic
 Issue Date: March-23
 Revisions: May-23 Δ1

Item Number: **(B) PA-502**
 Item Name: Bathroom Mirror
 Area Name: Public Area - Bathroom

Manufacturer:	Majestic Mirror	PI Fine Art	Wendover Art Group
Address:	7425 N.W. 79th Street Miami, FL 33166	1180 Caledonia Road Toronto, Ontario M6A 2W5	6465 126th Ave N Largo, Florida 33773
Phone:	305-827-2661 x106	416-789-7156 x255	727-573-1417
Contact:	Adam Jaffe	Elise Vandembosch	Carmine Giso
E-mail:	adam@majesticmirror.com	hilton@pifineart.com	hilton@wendoverart.com
Web:	www.kalisher.com	www.pifineart.com	www.wendoverart.com

Description: Framed Vanity Mirror @ Guest Room Bathroom, 3/16" Clear Float Mirror
 Dimensions: 24" W x 30"H
 Bevel: Clean Cut Polished; No Bevel
 Frame: Profile: Michelangelo Avant-Garde Series 41, Square, Dimensions: 1 1/4"W x 1 1/8"H
 Finish: Michelangelo 41-29 Black
 Orientation: Horizontal
 Mounting Height: See Prototype Drawings
 Hardware: "T" Security; 3-point
 Notes: Provide vinyl mirror safety backing with ANSI Safety backed, corrugated sheet and moisture barrier tape.



Unless Using A Specified Manufacturer, Submit The Following Required Item(s) for Approval Prior to Fabrication:
Finish Sample

Manufacturer to confirm the Product meets Hilton Design and Construction Standards as noted in Section 2515.06

Instructions:

- All quantities to be verified by hotel operator prior to purchasing.
- It is the responsibility of the owner to interpret these specifications for each property.
- All interpretations of the specification MUST be submitted to Hilton Design Review (projecthub.hilton.com) for final approval prior to purchasing or implementation of any material.
- Must be of contract quality and suitable for commercial use.
- All materials and methods of construction must comply with all local fire and life safety codes for use in hotels and other public spaces, and Brand Standards.
- Provide all parts, pieces and instructions for complete installation. Mounting method to be sufficient for weight of piece.
- All pieces must be crated for shipping. All corners should be wrapped with corner guards. Crates should be labeled with instructions for shipment, storage and opening of crate.
- For mirrors over 48" in any direction, provide inner frame and crossbracing.
- Manufacturer to provide 3-point or continuous cleat security cleating system appropriate for the size and weight of the mirror.
- Manufacturer to clearly mark each carton with item ID and specification number.



Project Name: Home2 Prototype FF&E Specifications
 Scheme: B-Dynamic
 Issue Date: March-23
 Revisions: May-23 Δ1

Item Number: **(B) PA-503**
 Item Name: Meeting Space Artwork
 Area Name: Public Area - Meeting Space

Manufacturer:	Kalisher	PI Fine Art	Wendover Art Group
Address:	800 Taylor Street, Suite 9A-154 Durham, NC 27701	1180 Caledonia Road Toronto, Ontario M6A 2W5	6465 126th Ave N Largo, Florida 33773
Phone:	919-967-4300 x123	416-789-7156 x255	727-573-1417
Contact:	Claire Sugg	Elise Vandebosch	Carmine Giso
E-mail:	c.sugg@kalisher.com	hilton@pifineart.com	hilton@wendoverart.com
Web:	www.kalisher.com	www.pifineart.com	www.wendoverart.com

Description: Framed Prints @ Three Bay Meeting Room
 Dimensions: 36"W x 36" H , Quantity of 3
 Molding Number: Michelangelo 41-29
 Molding Width: 1 1/4"W x 1 1/8"H
 Finish: Michelangelo Avant-Garde 41-29
 Orientation: Vertical
 Mounting Height: See architectural drawings
 Hardware: 3 Point Security Hardware
 Notes: See Design Guide for artwork content requirements.



Unless Using A Specified Manufacturer, Submit The Following Required Item(s) for Approval Prior to Fabrication:
Finish Sample **Shop Drawing**

Manufacturer to confirm the Product meets Hilton Design and Construction Standards as noted in Section 2515.05

Instructions:

- All quantities to be verified by hotel operator prior to purchasing.
- It is the responsibility of the owner to interpret these specifications for each property.
- All interpretations of the specification MUST be submitted to Hilton Design Review (projecthub.hilton.com) for final approval prior to purchasing or implementation of any material.
- Must be of contract quality and suitable for commercial use.
- All materials and methods of construction must comply with all local fire and life safety codes for use in hotels and other public spaces, and Brand Standards.
- Manufacturer to provide all component parts for complete assembly and installation.
- Mounting method to be sufficient for weight of piece.
- All pieces must be crated for shipping. All corners should be wrapped with corner guards. Crates should be labeled with instructions for shipment, storage and opening of crate.
- Manufacturer to provide 3-point or continuous cleat security cleating system appropriate for the size and weight of the artwork.
- Manufacturer to clearly mark each carton with item ID and specification number.
- Provide 1/4" (6mm) backer sheet, gator foam or tempered Masonite.
- Wood frames to be certified sustainable sources. All stress joints to be connected by double doweled, screwed and glued corner reinforcement.
- Must adhere to CARB Title 17 Standards: formaldehyde emissions for hardwood plywood, particleboard, and medium density fiberboard may not exceed .05ppm.



Project Name: Home2 Prototype FF&E Specifications
Scheme: B-Dynamic
Issue Date: March-23
Revisions: May-23 Δ1

Item Number: **(B) PA-503**
Item Name: Meeting Space Artwork
Area Name: Public Area - Meeting Space

-
- Finish goods containing composite wood products must comply with California Code of Regulations 93120. Product and carton will be labeled in accordance with this regulation.



Project Name: Home2 Prototype FF&E Specifications
 Scheme: B-Dynamic
 Issue Date: March-23
 Revisions: May-23 Δ1

Item Number: **(B) PA-504**
 Item Name: Boardroom Artwork
 Area Name: Public Area - Boardroom

Manufacturer:	Kalisher	PI Fine Art	Wendover Art Group
Address:	800 Taylor Street, Suite 9A-154 Durham, NC 27701	1180 Caledonia Road Toronto, Ontario M6A 2W5	6465 126th Ave N Largo, Florida 33773
Phone:	919-967-4300 x123	416-789-7156 x255	727-573-1417
Contact:	Claire Sugg	Elise Vandebosch	Carmine Giso
E-mail:	c.sugg@kalisher.com	hilton@pifineart.com	hilton@wendoverart.com
Web:	www.kalisher.com	www.pifineart.com	www.wendoverart.com

Description: Framed Print @ One Bay Meeting Room
 Dimensions: 36"W x 36" H
 Molding Number: Michelangelo 41-29
 Molding Width: 1 1/4"W x 1 1/8"H
 Finish: Michelangelo Avant-Garde 41-29
 Orientation: Vertical
 Mounting Height: See architectural drawings
 Hardware: 3 Point Security Hardware
 Notes: See Design Guide for artwork content requirements.



Unless Using A Specified Manufacturer, Submit The Following Required Item(s) for Approval Prior to Fabrication:
Finish Sample **Shop Drawing**

Manufacturer to confirm the Product meets Hilton Design and Construction Standards as noted in Section 2515.05

Instructions:

- All quantities to be verified by hotel operator prior to purchasing.
- It is the responsibility of the owner to interpret these specifications for each property.
- All interpretations of the specification MUST be submitted to Hilton Design Review (projecthub.hilton.com) for final approval prior to purchasing or implementation of any material.
- Must be of contract quality and suitable for commercial use.
- All materials and methods of construction must comply with all local fire and life safety codes for use in hotels and other public spaces, and Brand Standards.
- Manufacturer to provide all component parts for complete assembly and installation.
- Mounting method to be sufficient for weight of piece.
- All pieces must be crated for shipping. All corners should be wrapped with corner guards. Crates should be labeled with instructions for shipment, storage and opening of crate.
- Manufacturer to provide 3-point or continuous cleat security cleating system appropriate for the size and weight of the artwork.
- Manufacturer to clearly mark each carton with item ID and specification number.
- Provide 1/4" (6mm) backer sheet, gator foam or tempered Masonite.
- Wood frames to be certified sustainable sources. All stress joints to be connected by double doweled, screwed and glued corner reinforcement.
- Must adhere to CARB Title 17 Standards: formaldehyde emissions for hardwood plywood, particleboard, and medium density fiberboard may not exceed .05ppm.



Project Name: Home2 Prototype FF&E Specifications
Scheme: B-Dynamic
Issue Date: March-23
Revisions: May-23 Δ1

Item Number: **(B) PA-504**
Item Name: Boardroom Artwork
Area Name: Public Area - Boardroom

-
- Finish goods containing composite wood products must comply with California Code of Regulations 93120. Product and carton will be labeled in accordance with this regulation.

Project Name: Home2 Prototype FF&E Specifications Item Number: **(B) PA-505**
 Scheme: B-Dynamic Item Name: Guest Engagement Wall Artwork
 Issue Date: March-23
 Revisions: May-23 Δ1 Area Name: Public Area - Lobby

Manufacturer: **PI Fine Art**
 Address: 1180 Caledonia Road
 Toronto, Ontario M6A 2W5
 Phone: 416-789-7156 x255
 Contact: Elise Vandebosch
 E-mail: hilton@pifineart.com
 Web: www.pifineart.com

Description: Guest Engagement Wall to be Composed of 8 Varying Pieces of Art. One Interactive, One Team Member Engagement and a Mix of Dimensional and Framed Artwork Pieces as required. Artwork Images to be Reflective of Modern Traditionalist Influence while Adhering to Home2 Brand Characteristics and Scheme Colorationss. Images are to be Selected from a Specially Curated Image Bank Through the Specified Art Vendor.

Artwork A: Round print on 5/8" birch wood with raw wood edges
 Overall Size: 12" dia.

Orientation: NA/ Round

Hardware: 3 Point Security Hardware

Artwork B: Framed paper print

Overall Size: 18"W x 24"H

Orientation: Vertical

Frame: 1 1/4" Black Frame

Mat: 1.5" Visible Polar White mat

Hardware: 3 Point Security Hardware

Artwork C (Team Member Opt.): Linen wrapped corkboard and postcards
 Overall Size: 60"W x 30"H

Orientation: Horizontal

Frame: 1 5/8" Black Frame

Hardware: 3 Point Security Hardware

Includes 210 cards (50 of each of the Guest Interactive cards, 10 art cards), and 100 pins

Artwork D: 1/4" Acrylic forms with imagery mounted on brushed silver standoffs

Overall Size: 32"W x 20"H

Orientation: Horizontal

Hardware: Brushed Silver Standoffs

Cut to shape with some areas clear so wall beyond is visible.

Artwork E (Guest Interactive): Framed laminated paper print with magnetic backer
 Overall Size: 16"W x 16"D

Orientation: NA/Square

Frame: 1 1/4" Black Frame

Hardware: 3 Point Security Hardware

Artwork F: Unframed canvas on masonite backing

Overall Size: 23"W x 23"D

Orientation: NA/Square

Hardware: 3 Point Security Hardware

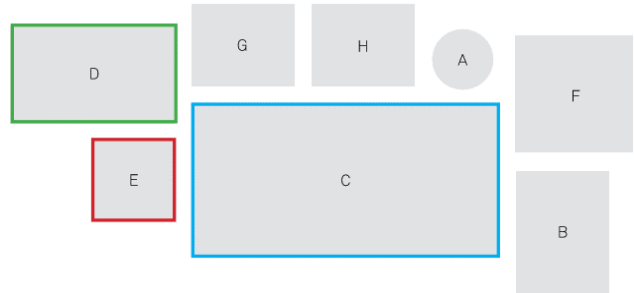



Project Name: Home2 Prototype FF&E Specifications Item Number: **(B) PA-505**
Scheme: B-Dynamic Item Name: Guest Engagement Wall Artwork
Issue Date: March-23
Revisions: May-23 Δ1 Area Name: Public Area - Lobby

Artwork G: Framed paper print
Overall Size: 20"W x 16"H
Orientation: Horizontal
Frame: 1 1/4" Black Frame
Hardware: 3 Point Security Hardware

Artwork H: Framed canvas
Overall Size: 20"W x 16"D
Orientation: Horizontal
Frame: 1/2" Black Floater Frame
Hardware: 3 Point Security Hardware

Image Size: See Description Above
Framed Size: See Description Above
Molding Number: See Description Above
Molding Width: See Description Above
Hardware: See Description Above
Notes: See Design Guide for artwork content requirements.

Unless Using A Specified Manufacturer, Submit The Following Required Item(s) for Approval Prior to Fabrication:

Finish Sample **Shop Drawing**

Manufacturer to confirm the Product meets Hilton Design and Construction Standards as noted in Section 2515.05

Instructions:

- All quantities to be verified by hotel operator prior to purchasing.
- It is the responsibility of the owner to interpret these specifications for each property.
- All interpretations of the specification MUST be submitted to Hilton Design Review (projecthub.hilton.com) for final approval prior to purchasing or implementation of any material.
- Must be of contract quality and suitable for commercial use.
- All materials and methods of construction must comply with all local fire and life safety codes for use in hotels and other public spaces, and Brand Standards.
- Manufacturer to provide all component parts for complete assembly and installation.
- Mounting method to be sufficient for weight of piece.
- All pieces must be crated for shipping. All corners should be wrapped with corner guards. Crates should be labeled with instructions for shipment, storage and opening of crate.
- Manufacturer to provide 3-point or continuous cleat security cleating system appropriate for the size and weight of the artwork.
- Manufacturer to clearly mark each carton with item ID and specification number.
- Provide 1/4" (6mm) backer sheet, gator foam or tempered Masonite.
- Wood frames to be certified sustainable sources. All stress joints to be connected by double doveled, screwed and glued corner reinforcement.
- Must adhere to CARB Title 17 Standards: formaldehyde emissions for hardwood plywood, particleboard, and medium density fiberboard may not exceed .05ppm.
- Finish goods containing composite wood products must comply with California Code of Regulations 93120. Product and carton will be labeled in accordance with this regulation.



Project Name: Home2 Prototype FF&E Specifications
Scheme: B-Dynamic
Issue Date: June-23

Item Number: **(B) PA-506**
Item Name: Fitness Wall Hooks
Area Name: Public Area - Fitness Room

Manufacturer: **WingIts Innovations, LLC**
Address: 3399 E. Grand River Ave, Ste. 100
Howell, MI 48843

Phone: 517-225-5225
Contact: Karen Cox
E-mail: dburcon@wingits.com
Web: www.wingits.com

Description: Wall Hooks @ Fitness Room
Model Name: MAX Elegance Single Button Robe Hook
Model Number: WXESBRHSN
Dimensions: 2" Dia. x 2"H x 2.25"D
Finish: Satin Stainless Steel
Orientation: Horizontal
Mounting Height: See architectural drawings
Notes: Manufacturer to provide mounting hardware.



Unless Using A Specified Manufacturer, Submit The Following Required Item(s) for Approval Prior to Fabrication:
Finish Sample **Shop Drawing**

Manufacturer to confirm the Product meets Hilton Design and Construction Standards as noted in Section 2515.05

Instructions:

- All quantities to be verified by hotel operator prior to purchasing.
- It is the responsibility of the owner to interpret these specifications for each property.
- All interpretations of the specification MUST be submitted to Hilton Design Review (projecthub.hilton.com) for final approval prior to purchasing or implementation of any material.
- Must be of contract quality and suitable for commercial use.
- All materials and methods of construction must comply with all local fire and life safety codes for use in hotels and other public spaces, and Brand Standards.
- Manufacturer to provide all necessary hardware for each item. All internal hardware (hinges, screws, bolts, etc.) shall be corrosion proof.
- Provide all parts, pieces and instructions for complete installation. Mounting method to be sufficient for weight of piece.
- Show all pieces in shop drawings. Provide reproducible scaled shop drawings to Hotel Operator Representative prior to production.
- All corners of metal frame to be mitered; All welds to be filled and fully finished; Grind and smooth all edges; No visible welds, seams, or burn marks; Seal as required.
- Manufacturer to clearly mark each carton with item ID and specification number.

Project Name: Home2 Prototype FF&E Specifications Item Number: **(B) OF-700**
 Scheme: B-Dynamic Item Name: Bench Seating @ Outdoor Lounge
 Issue Date: March-23
 Revisions: May-23 Δ1 Area Name: Outdoor- Outdoor Lounge

Manufacturer: **Walter's Wicker**
 Address: 120 North Street
 Teterboro, NJ 07608
 Phone: 201-286-9878
 Contact: Adam Schindler
 E-mail: home2@walterswicker.com
 Web: www.walterswicker.com

Description: Rectangular Bench with Cushions at Outdoor Lounge
 Composed of Four 72" Benches



Model Name/No.: WE-BOCA-43084
 Material/Finish: Powder coated aluminum frame M2 Matte Ebony
 Overall Dimension: Outdoor Lounge: 288" W x 32" D x 30" H
 Seat Height: 18"

Seat Cushion Style: Attached and removable
 Back Cushion Style: Attached and removable
 Cushion Content: All foam, filling and water resistant muslin wrap shall be fire retardant to meet all applicable codes. Must pass NFPA 260 / CAL 117.

COM/COL: Manufacturer: Giati
 Pattern: Writer's Retreat
 Color: Ash #9053
 Finish: Teflon
 Fire Rating: CAL117-2013, NFPA 260
 Content: 100% Solution Dyed Acrylic
 Width: 60"
 Repeat: NA
 Double Rubs: 20,000
 Backing: None
 Railroad: No

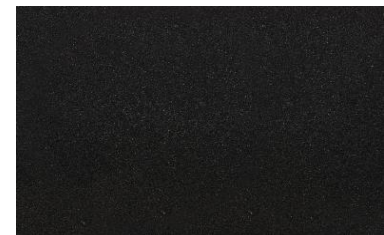

Metal Finish

Notes: For coastal and high wind conditions, all outdoor furniture must be weighted accordingly.

Unless Using A Specified Manufacturer, Submit The Following Required Item(s) for Approval Prior to Fabrication:

Finish Sample **Cutting** **Shop Drawing**

Manufacturer to confirm the Product meets Hilton Design and Construction Standards as noted in Section 2515.00

Instructions:

- All quantities to be verified by hotel operator prior to purchasing.
- It is the responsibility of the owner to interpret these specifications for each property.
- All interpretations of the specification MUST be submitted to Hilton Design Review (projecthub.hilton.com) for final approval prior to purchasing or implementation of any material.
- Must be of contract quality and suitable for commercial use.
- COM quantities must be verified by fabricator prior to ordering.
- All materials and methods of construction must comply with all local fire and life safety codes for use in hotels and other public spaces, and Home2 Brand Standards.
- All internal hardware (hinges, screws, bolts, etc.) shall be corrosion proof.
- Wood frames to be certified sustainable sources. All stress joints to be connected by double doveled, screwed and glued corner reinforcement.



Project Name: Home2 Prototype FF&E Specifications
Scheme: B-Dynamic
Issue Date: March-23
Revisions: May-23 Δ1

Item Number: **(B) OF-700**
Item Name: Bench Seating @ Outdoor Lounge
Area Name: Outdoor- Outdoor Lounge

- Manufacturer to provide nylon carpet glides when applicable.
- All foam, batting, padding, and Dacron wrap shall be fire retardant to meet all applicable codes.
- Cushions to be adequately vented for displacement of air and to provide increased comfort.
- Ensure that upholstered goods will fit in elevators and through doors prior to commencing fabrication.
- Entire frame and upholstery shall be inspected during the manufacturing and again after final assembly. Tailoring shall be neat, trim and performed in a professional manner.
- Manufacturer to clearly mark each carton with item ID and specification number.
- Manufacturer to verify all necessary parts, hardware with each item.

Project Name: Home2 Prototype FF&E Specifications
 Scheme: B-Dynamic
 Issue Date: March-23
 Revisions: May-23 Δ1

Item Number: **(B) OF-701**
 Item Name: Bench Seating @ Outdoor Lounge Firepit
 Area Name: Outdoor- Outdoor Lounge

Manufacturer: **Walter's Wicker**
 Address: 120 North Street
 Teterboro, NJ 07608
 Phone: 201-286-9878
 Contact: Adam Schindler
 E-mail: home2@walterswicker.com
 Web: www.walterswicker.com

Description: L-Shaped Bench with Cushions at Outdoor Lounge Firepit

Model Name/No.: Straight Unit: WE-43029-72
 Corner Unit: WE-430299
 Material/Finish: Powder coated aluminum frame M2 Matte Ebony
 Overall Dimension: 120"W x 120"D x 30"H
 Two Straight Units at 72"W x 31"D x 30"H
 One Corner Unit at 48"W x 48"D



Seat Height: 18"
 Seat Cushion Style: Attached and removable
 Back Cushion Style: Attached and removable
 Cushion Content: All foam, filling and water resistant muslin wrap shall be fire retardant to meet all applicable codes. Must pass NFPA 260 / CAL 117.



COM/COL: Manufacturer: Giati
 Pattern: Writer's Retreat
 Color: Ash #9053
 Finish: Teflon
 Fire Rating: CAL117-2013, NFPA 260
 Content: 100% Solution Dyed Acrylic
 Width: 60"
 Repeat: NA
 Double Rubs: 20,000
 Backing: None
 Railroad: No

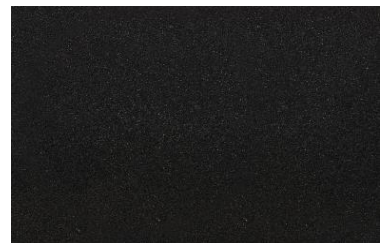

Metal Finish

Notes: For coastal and high wind conditions, all outdoor furniture must be weighted accordingly.

Unless Using A Specified Manufacturer, Submit The Following Required Item(s) for Approval Prior to Fabrication:

Finish Sample **Cutting** **Shop Drawing**

Manufacturer to confirm the Product meets Hilton Design and Construction Standards as noted in Section 2515.00

Instructions:

- All quantities to be verified by hotel operator prior to purchasing.
- It is the responsibility of the owner to interpret these specifications for each property.
- All interpretations of the specification MUST be submitted to Hilton Design Review (projecthub.hilton.com) for final approval prior to purchasing or implementation of any material.
- Must be of contract quality and suitable for commercial use.
- COM quantities must be verified by fabricator prior to ordering.
- All materials and methods of construction must comply with all local fire and life safety codes for use in hotels and other public spaces, and Home2 Brand Standards.



Project Name: Home2 Prototype FF&E Specifications
Scheme: B-Dynamic
Issue Date: March-23
Revisions: May-23 Δ1

Item Number: **(B) OF-701**
Item Name: Bench Seating @ Outdoor Lounge
Firepit
Area Name: Outdoor- Outdoor Lounge

- All internal hardware (hinges, screws, bolts, etc.) shall be corrosion proof.
- Wood frames to be certified sustainable sources. All stress joints to be connected by double doweled, screwed and glued corner reinforcement.
- Manufacturer to provide nylon carpet glides when applicable.
- All foam, batting, padding, and Dacron wrap shall be fire retardant to meet all applicable codes.
- Cushions to be adequately vented for displacement of air and to provide increased comfort.
- Ensure that upholstered goods will fit in elevators and through doors prior to commencing fabrication.
- Entire frame and upholstery shall be inspected during the manufacturing and again after final assembly. Tailoring shall be neat, trim and performed in a professional manner.
- Manufacturer to clearly mark each carton with item ID and specification number.
- Manufacturer to verify all necessary parts, hardware with each item.



Project Name: Home2 Prototype FF&E Specifications
Scheme: B-Dynamic
Issue Date: March-23
Revisions:

Item Number: **(B) OF -702**
Item Name: Arm Chair @ Outdoor Lounge
Area Name: Outdoor- Outdoor Lounge

Manufacturer: **SIT Outdoor**
Address: 41 Franklin St
Quincy, MA 02169
Phone: 617-479-6362 x104
Contact: Lauren Renga
E-mail: lrenga@sitoutdoor.com
Web: www.sitoutdoor.com

Description: Arm Chair at Outdoor Lounge
Model Name/No: Nardi Net Relax 40327.04.000
Material/Finish: Fiberglass polypropylene resin matte finish, color Salice.04
Overall Dimension: 26.4"W X 28"D x 34"H
Seat Height: 17 3/4"
Seat Cushion Style: NA
Back Cushion Style: NA
Cushion Content: NA
COM/COL: NA



Notes: For coastal and high wind conditions, all outdoor furniture must be weighted accordingly.

Unless Using A Specified Manufacturer, Submit The Following Required Item(s) for Approval Prior to Fabrication:

Finish Sample **Shop Drawing**

Manufacturer to confirm the Product meets Hilton Design and Construction Standards as noted in Section 2515.00

Instructions:

- All quantities to be verified by hotel operator prior to purchasing.
- It is the responsibility of the owner to interpret these specifications for each property.
- All interpretations of the specification MUST be submitted to Hilton Design Review (projecthub.hilton.com) for final approval prior to purchasing or implementation of any material.
- Must be of contract quality and suitable for commercial use.
- COM quantities must be verified by fabricator prior to ordering.
- All materials and methods of construction must comply with all local fire and life safety codes for use in hotels and other public spaces, and Home2 Brand Standards.
- All internal hardware (hinges, screws, bolts, etc.) shall be corrosion proof.
- Wood frames to be certified sustainable sources. All stress joints to be connected by double doweled, screwed and glued corner reinforcement.
- Manufacturer to provide nylon carpet glides when applicable.
- All foam, batting, padding, and Dacron wrap shall be fire retardant to meet all applicable codes.
- Cushions to be adequately vented for displacement of air and to provide increased comfort.
- Ensure that upholstered goods will fit in elevators and through doors prior to commencing fabrication.
- Entire frame and upholstery shall be inspected during the manufacturing and again after final assembly. Tailoring shall be neat, trim and performed in a professional manner.
- Manufacturer to clearly mark each carton with item ID and specification number.
- Manufacturer to verify all necessary parts, hardware with each item.

Project Name: Home2 FF&E Specifications Item Number: **(B) OF -703**
 Scheme: B-Dynamic Item Name: Lounge Chair @ Outdoor Lounge
 Issue Date: March-23 Firepit
 Revisions: Area Name: Outdoor - Outdoor Lounge Firepit

Manufacturer: **SIT Outdoor**
 Address: 41 Franklin St
 Quincy, MA 02169
 Phone: 617-479-6362 x104
 Contact: Lauren Renga
 E-mail: lrenga@sitoutdoor.com
 Web: www.sitoutdoor.com

Description: Lounge Chair at Outdoor Lounge Firepit
 Model Name/No: Nardi Net Lounge 40329.02.000
 Material/Finish: Fiberglass polypropylene resin matte finish, color Anthracite .02
 Overall Dimension: 24"W X 35"D x 37.8"H
 Seat Height: 16 1/2"
 Arm Height: 20 3/4"
 Seat Cushion Style: NA
 Back Cushion Style: NA
 Cushion Content: NA
 COM/COL: NA
 Notes: For coastal and high wind conditions, all outdoor furniture must be weighted accordingly.



Unless Using A Specified Manufacturer, Submit The Following Required Item(s) for Approval Prior to Fabrication:

Finish Sample **Shop Drawing**

Manufacturer to confirm the Product meets Hilton Design and Construction Standards as noted in Section 2515.00

Instructions:

- All quantities to be verified by hotel operator prior to purchasing.
- It is the responsibility of the owner to interpret these specifications for each property.
- All interpretations of the specification MUST be submitted to Hilton Design Review (projecthub.hilton.com) for final approval prior to purchasing or implementation of any material.
- Must be of contract quality and suitable for commercial use.
- COM quantities must be verified by fabricator prior to ordering.
- All materials and methods of construction must comply with all local fire and life safety codes for use in hotels and other public spaces, and Home2 Brand Standards.
- All internal hardware (hinges, screws, bolts, etc.) shall be corrosion proof.
- Wood frames to be certified sustainable sources. All stress joints to be connected by double doweled, screwed and glued corner reinforcement.
- Manufacturer to provide nylon carpet glides when applicable.
- All foam, batting, padding, and Dacron wrap shall be fire retardant to meet all applicable codes.
- Cushions to be adequately vented for displacement of air and to provide increased comfort.
- Ensure that upholstered goods will fit in elevators and through doors prior to commencing fabrication.
- Entire frame and upholstery shall be inspected during the manufacturing and again after final assembly. Tailoring shall be neat, trim and performed in a professional manner.
- Manufacturer to clearly mark each carton with item ID and specification number.
- Manufacturer to verify all necessary parts, hardware with each item.

Project Name: Home2 FF&E Specifications Item Number: **(B) OF-704**
 Scheme: B-Dynamic Item Name: Ottoman Outdoor Lounge Firepit
 Issue Date: March-23
 Revisions: May-23 Δ1 Area Name: Outdoor - Outdoor Lounge Firepit

Manufacturer: **Walter's Wicker**
 Address: 120 North Street
 Teterboro, NJ 07608
 Phone: 201-286-9878
 Contact: Adam Schindler
 E-mail: home2@walterswicker.com
 Web: www.walterswicker.com

Description: Ottoman at Outdoor Lounge Firepit with Cushion Top
 Model Name/No: Fulton Side Table with Cushion Top/WEC-CHAM-11011
 Material/Finish: Powder coated aluminum frame, color M2 Matte Ebony with woven rope, color Medallion FX73
 Overall Dimension: 23"W x 18"H
 Arm Height: NA
 Seat Height: NA
 Seat Cushion Style: Attached and removable
 Back Cushion Style: NA
 Cushion Content: All foam, filling and water resistant muslin wrap shall be fire retardant to meet all applicable codes. Must pass NFPA 260 / CAL 117.
 COM/COL: Manufacturer: Giati
 Pattern: Writer's Retreat
 Color: Sky Blue #9157
 Finish: Teflon
 Fire Rating: CAL117-2013, NFPA 260
 Content: 100% Solution Dyed Acrylic
 Width: 60"
 Repeat: NA
 Double Rubs: 20,000
 Backing: None
 Railroad: No

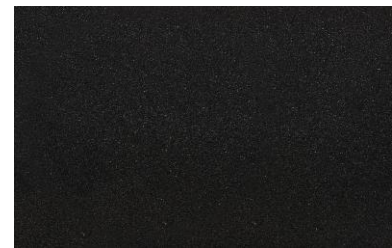

Metal Finish

Notes: For coastal and high wind conditions, all outdoor furniture must be weighted accordingly.

Unless Using A Specified Manufacturer, Submit The Following Required Item(s) for Approval Prior to Fabrication:

Finish Sample **Cutting** **Shop Drawing**

Manufacturer to confirm the Product meets Hilton Design and Construction Standards as noted in Section 2515.00

Instructions:

- All quantities to be verified by hotel operator prior to purchasing.
- It is the responsibility of the owner to interpret these specifications for each property.
- All interpretations of the specification MUST be submitted to Hilton Design Review (projecthub.hilton.com) for final approval prior to purchasing or implementation of any material.
- Must be of contract quality and suitable for commercial use.
- COM quantities must be verified by fabricator prior to ordering.
- All materials and methods of construction must comply with all local fire and life safety codes for use in hotels and other public spaces, and Home2 Brand Standards.
- All internal hardware (hinges, screws, bolts, etc.) shall be corrosion proof.



Project Name: Home2 FF&E Specifications

Item Number: **(B) OF-704**

Scheme: B-Dynamic

Item Name: Ottoman Outdoor Lounge Firepit

Issue Date: March-23

Revisions: May-23 Δ1

Area Name: Outdoor - Outdoor Lounge Firepit

- Wood frames to be certified sustainable sources. All stress joints to be connected by double doveled, screwed and glued corner reinforcement.
- Manufacturer to provide nylon carpet glides when applicable.
- All foam, batting, padding, and Dacron wrap shall be fire retardant to meet all applicable codes.
- Cushions to be adequately vented for displacement of air and to provide increased comfort.
- Ensure that upholstered goods will fit in elevators and through doors prior to commencing fabrication.
- Entire frame and upholstery shall be inspected during the manufacturing and again after final assembly. Tailoring shall be neat, trim and performed in a professional manner.
- Manufacturer to clearly mark each carton with item ID and specification number.
- Manufacturer to verify all necessary parts, hardware with each item.

Project Name: Home2 FF&E Specifications
 Scheme: B-Dynamic
 Issue Date: March-23
 Revisions:

Item Number: **(B) OF-705**
 Item Name: 2 Top Table @ Outdoor Lounge & Grilling Patio
 Area Name: Outdoor - Outdoor Lounge & Grilling Patio

Manufacturer: **Emuamericas**
 Address: 4465 Kipling St Suite 201
 Wheat Ridge, CO 80033
 Phone: 303-733-3385 x220
 Contact: Katarina Triska
 E-mail: ktriska@emuamericas.com
 Web: www.emuamericas.com

Description: 2 Top Table at Outdoor Lounge and Grilling Patio
 Model Name/No.: Darwin #529
 Width: 32"
 Depth: 32"
 Height: 29"
 Top Thickness: 3/4"
 Top Material/Finish: Powder coated steel, color A/Black 24
 Base Material/Finish: Powder coated steel, color A/Black 24
 Notes: Tilt top nesting table
 For coastal and high wind conditions, all outdoor furniture must be weighted accordingly.



Metal Finish



Unless Using A Specified Manufacturer, Submit The Following Required Item(s) for Approval Prior to Fabrication:
Finish Sample **Shop Drawing**

Manufacturer to confirm the Product meets Hilton Design and Construction Standards as noted in Section 2515.00

Instructions:

- All quantities to be verified by hotel operator prior to purchasing.
- It is the responsibility of the owner to interpret these specifications for each property.
- All interpretations of the specification MUST be submitted to Hilton Design Review (projecthub.hilton.com) for final approval prior to purchasing or implementation of any material.
- Must be of contract quality and suitable for commercial use.
- All materials and methods of construction must comply with all local fire and life safety codes and Brand Standards.
- Manufacturer to provide all necessary hardware for each item. All internal hardware (hinges, screws, bolts, etc.) shall be corrosion proof.
- Major joints as needed shall utilize lap joints or double doweled construction with corner blocks. Glue and staples are used to reinforce the joinery.
- Metal fasteners should be used where appropriate to ensure commercial frame strength.
- Manufacturer to verify all necessary parts, hardware and dimensions required for assembly.
- All wood to be kiln dried and treated to be insect and vermin free.
- Ensure that all pieces will fit in elevators and through doors prior to commencing fabrication.
- Show all pieces in shop drawings. Provide reproducible scaled shop drawings to Hotel Operator Representative prior to production.
- Provide clear alcohol and water-resistant penetrating sealer as required at wood.
- Solid hardwood frames to be certified sustainable sources. All stress joints to be connected by double doweled, screwed and glued corner reinforcement.



Project Name: Home2 FF&E Specifications
Scheme: B-Dynamic
Issue Date: March-23
Revisions:

Item Number: **(B) OF-705**
Item Name: 2 Top Table @ Outdoor Lounge & Grilling Patio
Area Name: Outdoor - Outdoor Lounge & Grilling Patio

-
- All corners of metal frame to be mitered; All welds to be filled and fully finished; Grind and smooth all edges; No visible welds, seams, or burn marks; Seal as required.
 - Finish goods containing composite wood products must comply with California Code of Regulations 93120. Product and carton will be labeled in accordance with this regulation.
 - Manufacturer to clearly mark each carton with item ID and specification number.

Project Name: Home2 FF&E Specifications
 Scheme: B-Dynamic
 Issue Date: March-23
 Revisions:

Item Number: **(B) OF-705-ADA**
 Item Name: ADA Table @ Grilling Patio
 Area Name: Outdoor - Outdoor Lounge & Grilling Patio

Manufacturer: **Emuamericas**
 Address: 4465 Kipling St Suite 201
 Wheat Ridge, CO 80033
 Phone: 303-733-3385 x220
 Contact: Katarina Triska
 E-mail: ktriska@emuamericas.com
 Web: www.emuamericas.com

Description: ADA Table at Grilling Patio
 Model Name/No.: Darwin ADA Table/3560
 Width: 41.5"
 Depth: 24"
 Height: 29.5"
 Top Thickness: 1.25"
 Top Material/Finish: Powder coated steel, color A/Black 24
 Base Material/Finish: Powder coated steel, color A/Black 24
 Notes: For coastal and high wind conditions, all outdoor furniture must be weighted accordingly.



Metal Finish



Unless Using A Specified Manufacturer, Submit The Following Required Item(s) for Approval Prior to Fabrication:

Finish Sample **Shop Drawing**

Manufacturer to confirm the Product meets Hilton Design and Construction Standards as noted in Section 2515.00

Instructions:

- All quantities to be verified by hotel operator prior to purchasing.
- It is the responsibility of the owner to interpret these specifications for each property.
- All interpretations of the specification MUST be submitted to Hilton Design Review (projecthub.hilton.com) for final approval prior to purchasing or implementation of any material.
- Must be of contract quality and suitable for commercial use.
- All materials and methods of construction must comply with all local fire and life safety codes and Brand Standards.
- Manufacturer to provide all necessary hardware for each item. All internal hardware (hinges, screws, bolts, etc.) shall be corrosion proof.
- Major joints as needed shall utilize lap joints or double doweled construction with corner blocks. Glue and staples are used to reinforce the joinery.
- Metal fasteners should be used where appropriate to ensure commercial frame strength.
- Manufacturer to verify all necessary parts, hardware and dimensions required for assembly.
- All wood to be kiln dried and treated to be insect and vermin free.
- Ensure that all pieces will fit in elevators and through doors prior to commencing fabrication.
- Show all pieces in shop drawings. Provide reproducible scaled shop drawings to Hotel Operator Representative prior to production.
- Provide clear alcohol and water-resistant penetrating sealer as required at wood.
- Solid hardwood frames to be certified sustainable sources. All stress joints to be connected by double doweled, screwed and glued corner reinforcement.
- All corners of metal frame to be mitered; All welds to be filled and fully finished; Grind and smooth all edges; No visible welds, seams, or burn marks; Seal as required.



Project Name: Home2 FF&E Specifications
Scheme: B-Dynamic
Issue Date: March-23
Revisions:

Item Number: **(B) OF-705-ADA**
Item Name: ADA Table @ Grilling Patio
Area Name: Outdoor - Outdoor Lounge & Grilling Patio

- Finish goods containing composite wood products must comply with California Code of Regulations 93120. Product and carton will be labeled in accordance with this regulation.
- Manufacturer to clearly mark each carton with item ID and specification number.

Project Name: Home2 FF&E Specifications
 Scheme: B-Dynamic
 Issue Date: March-23
 Revisions:

Item Number: **(B) OF-706**
 Item Name: Food Prep Table @ Grilling Patio
 Area Name: Outdoor - Grilling Patio

Manufacturer: **UNDER DEVELOPMENT**
 Address:

Phone:
 Contact:
 E-mail:
 Web:

Description: Grilling Table at Outdoor Grills
 Model Name/No.: Custom Food Prep Table
 Width: 33.5"
 Depth: 20"
 Height: 34"
 Top Thickness: NA
 Top Material/Finish: Food safe stainless steel
 Base Material/Finish: Food safe stainless steel
 Notes: For coastal and high wind conditions, all outdoor furniture must be weighted accordingly.



Unless Using A Specified Manufacturer, Submit The Following Required Item(s) for Approval Prior to Fabrication:

Finish Sample **Shop Drawing**

Manufacturer to confirm the Product meets Hilton Design and Construction Standards as noted in Section 2515.00

Instructions:

- All quantities to be verified by hotel operator prior to purchasing.
- It is the responsibility of the owner to interpret these specifications for each property.
- All interpretations of the specification MUST be submitted to Hilton Design Review (projecthub.hilton.com) for final approval prior to purchasing or implementation of any material.
- Must be of contract quality and suitable for commercial use.
- All materials and methods of construction must comply with all local fire and life safety codes and Brand Standards.
- Manufacturer to provide all necessary hardware for each item. All internal hardware (hinges, screws, bolts, etc.) shall be corrosion proof.
- Major joints as needed shall utilize lap joints or double doweled construction with corner blocks. Glue and staples are used to reinforce the joinery.
- Metal fasteners should be used where appropriate to ensure commercial frame strength.
- Manufacturer to verify all necessary parts, hardware and dimensions required for assembly.
- All wood to be kiln dried and treated to be insect and vermin free.
- Ensure that all pieces will fit in elevators and through doors prior to commencing fabrication.
- Show all pieces in shop drawings. Provide reproducible scaled shop drawings to Hotel Operator Representative prior to production.
- Provide clear alcohol and water-resistant penetrating sealer as required at wood.
- Solid hardwood frames to be certified sustainable sources. All stress joints to be connected by double doweled, screwed and glued corner reinforcement.
- All corners of metal frame to be mitered; All welds to be filled and fully finished; Grind and smooth all edges; No visible welds, seams, or burn marks; Seal as required.



Project Name: Home2 FF&E Specifications
Scheme: B-Dynamic
Issue Date: March-23

Item Number: **(B) OF-706**
Item Name: Food Prep Table @ Grilling Patio
Area Name: Outdoor - Grilling Patio

Revisions:

- Finish goods containing composite wood products must comply with California Code of Regulations 93120. Product and carton will be labeled in accordance with this regulation.
- Manufacturer to clearly mark each carton with item ID and specification number.

Project Name: Home2 FF&E Specifications
 Scheme: B-Dynamic
 Issue Date: March-23
 Revisions:

Item Number: **(B) OF-707**
 Item Name: Cocktail Table @ Outdoor Lounge
 Area Name: Outdoor - Outdoor Lounge

Manufacturer: **Emuamericas**
 Address: 4465 Kipling St Suite 201
 Wheat Ridge, CO 80033
 Phone: 303-733-3385 x220
 Contact: Katarina Triska
 E-mail: ktriska@emuamericas.com
 Web: www.emuamericas.com

Description: Cocktail Table at Outdoor Lounge
 Model Name/No.: Terramare Low Table #736
 Width: 29.5"
 Depth: 27.5"
 Height: 12"
 Top Material/Finish: Ceramic, Basaltina 34
 Base Material/Finish: Tubular aluminum, color A/Black 24
 Notes: For coastal and high wind conditions, all outdoor furniture must be weighted accordingly.

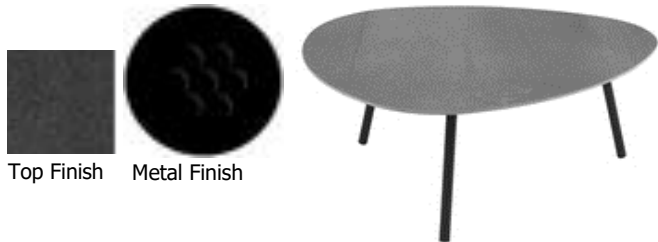

Unless Using A Specified Manufacturer, Submit The Following Required Item(s) for Approval Prior to Fabrication:
Finish Sample **Shop Drawing**

Manufacturer to confirm the Product meets Hilton Design and Construction Standards as noted in Section 2515.00

Instructions:

- All quantities to be verified by hotel operator prior to purchasing.
- It is the responsibility of the owner to interpret these specifications for each property.
- All interpretations of the specification MUST be submitted to Hilton Design Review (projecthub.hilton.com) for final approval prior to purchasing or implementation of any material.
- Must be of contract quality and suitable for commercial use.
- All materials and methods of construction must comply with all local fire and life safety codes and Brand Standards.
- Manufacturer to provide all necessary hardware for each item. All internal hardware (hinges, screws, bolts, etc.) shall be corrosion proof.
- Major joints as needed shall utilize lap joints or double doweled construction with corner blocks. Glue and staples are used to reinforce the joinery.
- Metal fasteners should be used where appropriate to ensure commercial frame strength.
- Manufacturer to verify all necessary parts, hardware and dimensions required for assembly.
- All wood to be kiln dried and treated to be insect and vermin free.
- Ensure that all pieces will fit in elevators and through doors prior to commencing fabrication.
- Show all pieces in shop drawings. Provide reproducible scaled shop drawings to Hotel Operator Representative prior to production.
- Provide clear alcohol and water-resistant penetrating sealer as required at wood.
- Solid hardwood frames to be certified sustainable sources. All stress joints to be connected by double doweled, screwed and glued corner reinforcement.
- All corners of metal frame to be mitered; All welds to be filled and fully finished; Grind and smooth all edges; No visible welds, seams, or burn marks; Seal as required.



Project Name: Home2 FF&E Specifications
Scheme: B-Dynamic
Issue Date: March-23

Item Number: **(B) OF-707**
Item Name: Cocktail Table @ Outdoor Lounge
Area Name: Outdoor - Outdoor Lounge

Revisions:

- Finish goods containing composite wood products must comply with California Code of Regulations 93120. Product and carton will be labeled in accordance with this regulation.
- Manufacturer to clearly mark each carton with item ID and specification number.

Project Name: Home2 FF&E Specifications
 Scheme: B-Dynamic
 Issue Date: March-23
 Revisions: May-23 Δ1

Item Number: **(B) OF -708**
 Item Name: Lounge Chair @ Outdoor Lounge
 Area Name: Outdoor - Outdoor Lounge

Manufacturer: **Walter's Wicker**
 Address: 120 North Street
 Teterboro, NJ 07608
 Phone: 201-286-9878
 Contact: Adam Schindler
 E-mail: home2@walterswicker.com
 Web: www.walterswicker.com

Description: Lounge chair at Outdoor Lounge
 Model Name/No: Fulton Lounge Chair/WEC-FUL-2003
 Material/Finish: Powder coated aluminum frame M2 Matte Ebony
 Overall Dimension: 32"W X 30"D x 29"H
 Seat Height: 19"
 Seat Cushion Style: Attached and removable
 Back Cushion Style: Attached and removable
 Cushion Content: All foam, filling and water resistant muslin wrap shall be fire retardant to meet all applicable codes. Must pass NFPA 260 / CAL 117.



COM/COL: Manufacturer: Giati
 Pattern: Writer's Retreat
 Color: Ash #9053
 Finish: Teflon
 Fire Rating: CAL117-2013, NFPA 260
 Content: 100% Solution Dyed Acrylic
 Width: 60"
 Repeat: NA
 Double Rubs: 20,000
 Backing: None
 Railroad: No



Notes: For coastal and high wind conditions, all outdoor furniture must be weighted accordingly.

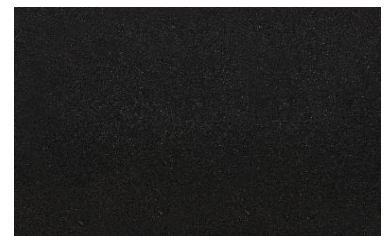

Metal Finish

Unless Using A Specified Manufacturer, Submit The Following Required Item(s) for Approval Prior to Fabrication:

Finish Sample **Cutting** **Shop Drawing**

Manufacturer to confirm the Product meets Hilton Design and Construction Standards as noted in Section 2515.00

Instructions:

- All quantities to be verified by hotel operator prior to purchasing.
- It is the responsibility of the owner to interpret these specifications for each property.
- All interpretations of the specification MUST be submitted to Hilton Design Review (projecthub.hilton.com) for final approval prior to purchasing or implementation of any material.
- Must be of contract quality and suitable for commercial use.
- COM quantities must be verified by fabricator prior to ordering.
- All materials and methods of construction must comply with all local fire and life safety codes for use in hotels and other public spaces, and Home2 Brand Standards.



Project Name: Home2 FF&E Specifications
Scheme: B-Dynamic
Issue Date: March-23
Revisions: May-23 Δ1

Item Number: **(B) OF -708**
Item Name: Lounge Chair @ Outdoor Lounge
Area Name: Outdoor - Outdoor Lounge

-
- All internal hardware (hinges, screws, bolts, etc.) shall be corrosion proof.
 - Wood frames to be certified sustainable sources. All stress joints to be connected by double doveled, screwed and glued corner reinforcement.
 - Manufacturer to provide nylon carpet glides when applicable.
 - All foam, batting, padding, and Dacron wrap shall be fire retardant to meet all applicable codes.
 - Cushions to be adequately vented for displacement of air and to provide increased comfort.
 - Ensure that upholstered goods will fit in elevators and through doors prior to commencing fabrication.
 - Entire frame and upholstery shall be inspected during the manufacturing and again after final assembly. Tailoring shall be neat, trim and performed in a professional manner.
 - Manufacturer to clearly mark each carton with item ID and specification number.
 - Manufacturer to verify all necessary parts, hardware with each item.

Project Name:	Home2 FF&E Specifications	Item Number:	(B) OF-709
Scheme:	B-Dynamic	Item Name:	Round Side Table @ Outdoor Lounge
Issue Date:	March-23	Area Name:	Outdoor - Outdoor Lounge
Revisions:	May-23 Δ1		

Manufacturer: **Walter's Wicker**
 Address: 120 North Street
 Teterboro, NJ 07608
 Phone: 201-286-9878
 Contact: Adam Schindler
 E-mail: home2@walterswicker.com
 Web: www.walterswicker.com

Description: Round Side Table at Outdoor Lounge with Flared Base
 Model Name/No.: Ezra Side Table/WEC-EZRA-20011
 Diameter: 18"
 Height: 14"
 Top Material/Finish: Aluminum, M70 Fiery Red
 Base Material/Finish: Aluminum, M70 Fiery Red
 Notes: For coastal and high wind conditions, all outdoor furniture must be weighted accordingly.



Metal Finish



Unless Using A Specified Manufacturer, Submit The Following Required Item(s) for Approval Prior to Fabrication:

Finish Sample **Shop Drawing**

Manufacturer to confirm the Product meets Hilton Design and Construction Standards as noted in Section 2515.00

Instructions:

- All quantities to be verified by hotel operator prior to purchasing.
- It is the responsibility of the owner to interpret these specifications for each property.
- All interpretations of the specification MUST be submitted to Hilton Design Review (projecthub.hilton.com) for final approval prior to purchasing or implementation of any material.
- Must be of contract quality and suitable for commercial use.
- All materials and methods of construction must comply with all local fire and life safety codes and Brand Standards.
- Manufacturer to provide all necessary hardware for each item. All internal hardware (hinges, screws, bolts, etc.) shall be corrosion proof.
- Major joints as needed shall utilize lap joints or double doweled construction with corner blocks. Glue and staples are used to reinforce the joinery.
- Metal fasteners should be used where appropriate to ensure commercial frame strength.
- Manufacturer to verify all necessary parts, hardware and dimensions required for assembly.
- All wood to be kiln dried and treated to be insect and vermin free.
- Ensure that all pieces will fit in elevators and through doors prior to commencing fabrication.
- Show all pieces in shop drawings. Provide reproducible scaled shop drawings to Hotel Operator Representative prior to production.
- Provide clear alcohol and water-resistant penetrating sealer as required at wood.
- Solid hardwood frames to be certified sustainable sources. All stress joints to be connected by double doweled, screwed and glued corner reinforcement.
- All corners of metal frame to be mitered; All welds to be filled and fully finished; Grind and smooth all edges; No visible welds, seams, or burn marks; Seal as required.
- Finish goods containing composite wood products must comply with California Code of Regulations 93120. Product and carton will be labeled in accordance with this regulation.



Project Name: Home2 FF&E Specifications
Scheme: B-Dynamic
Issue Date: March-23
Revisions: May-23 Δ1

Item Number: **(B) OF-709**
Item Name: Round Side Table @ Outdoor Lounge
Area Name: Outdoor - Outdoor Lounge

- Manufacturer to clearly mark each carton with item ID and specification number.

Project Name: Home2 FF&E Specifications
 Scheme: B-Dynamic
 Issue Date: March-23

Item Number: **(B) OF -710**
 Item Name: Counter Stool @ Grilling Patio
 Area Name: Outdoor - Grilling Patio

Revisions:

Manufacturer: **Emeco Industries**
 Address: 805 Elm Avenue
 Hanover, PA 17331
 Phone: 562-533-0031
 Contact: Chris Correll
 E-mail: chris@emeco.net
 Web: www.emeco.net

Description: Molded Outdoor Counter Height Stool with Metal Foot Rail
 Model Name/No: Broom Counter Stool
 Material/Finish: Broom 24 Dark Grey
 Overall Dimension: 16 1/2"W x 18 "D x 38"H
 Arm Height: NA
 Seat Height: 25"H
 Seat Cushion Style: NA
 Back Cushion Style: NA
 Cushion Content: NA
 COM/COL: NA



Notes: For coastal and high wind conditions, all outdoor furniture must be weighted accordingly.

Unless Using A Specified Manufacturer, Submit The Following Required Item(s) for Approval Prior to Fabrication:

Finish Sample **Shop Drawing**

Manufacturer to confirm the Product meets Hilton Design and Construction Standards as noted in Section 2515.00

Instructions:

- All quantities to be verified by hotel operator prior to purchasing.
- It is the responsibility of the owner to interpret these specifications for each property.
- All interpretations of the specification MUST be submitted to Hilton Design Review (projecthub.hilton.com) for final approval prior to purchasing or implementation of any material.
- Must be of contract quality and suitable for commercial use.
- COM quantities must be verified by fabricator prior to ordering.
- All materials and methods of construction must comply with all local fire and life safety codes for use in hotels and other public spaces, and Home2 Brand Standards.
- All internal hardware (hinges, screws, bolts, etc.) shall be corrosion proof.
- Wood frames to be certified sustainable sources. All stress joints to be connected by double doweled, screwed and glued corner reinforcement.
- Manufacturer to provide nylon carpet glides when applicable.
- All foam, batting, padding, and Dacron wrap shall be fire retardant to meet all applicable codes.
- Cushions to be adequately vented for displacement of air and to provide increased comfort.
- Ensure that upholstered goods will fit in elevators and through doors prior to commencing fabrication.

Project Name: Home2 FF&E Specifications
 Scheme: B-Dynamic
 Issue Date: March-23
 Revisions:

Item Number: **(B) OF -711**
 Item Name: Dining Chair @ Outdoor Lounge, Grilling Patio, & Pool
 Area Name: Outdoor - Lounge, Grilling Patio, & Pool

Manufacturer: **SIT Outdoor**
 Address: 41 Franklin St
 Quincy, MA 02169
 Phone: 617-479-6362 x104
 Contact: Lauren Renga
 E-mail: lrenga@sitoutdoor.com
 Web: www.sitoutdoor.com

Description: Dining Chair at Outdoor Lounge, Grilling Patio and Pool
 Model Name/No: Nardi Trill Bistro 40253.56.000
 Material/Finish: Fiberglass polypropylene resin matte finish, color Senape .56
 Overall Dimension: 19.7"W x 20.3"D x 32.5"H
 Arm Height: NA
 Seat Height: 18.5"
 Seat Cushion Style: NA
 Back Cushion Style: NA
 Cushion Content: NA
 COM/COL: NA



Notes: For coastal and high wind conditions, all outdoor furniture must be weighted accordingly.

Unless Using A Specified Manufacturer, Submit The Following Required Item(s) for Approval Prior to Fabrication:

Finish Sample **Shop Drawing**

Manufacturer to confirm the Product meets Hilton Design and Construction Standards as noted in Section 2515.00

Instructions:

- All quantities to be verified by hotel operator prior to purchasing.
- It is the responsibility of the owner to interpret these specifications for each property.
- All interpretations of the specification MUST be submitted to Hilton Design Review (projecthub.hilton.com) for final approval prior to purchasing or implementation of any material.
- Must be of contract quality and suitable for commercial use.
- COM quantities must be verified by fabricator prior to ordering.
- All materials and methods of construction must comply with all local fire and life safety codes for use in hotels and other public spaces, and Home2 Brand Standards.
- All internal hardware (hinges, screws, bolts, etc.) shall be corrosion proof.
- Wood frames to be certified sustainable sources. All stress joints to be connected by double doweled, screwed and glued corner reinforcement.
- Manufacturer to provide nylon carpet glides when applicable.
- All foam, batting, padding, and Dacron wrap shall be fire retardant to meet all applicable codes.
- Cushions to be adequately vented for displacement of air and to provide increased comfort.
- Ensure that upholstered goods will fit in elevators and through doors prior to commencing fabrication.
- Entire frame and upholstery shall be inspected during the manufacturing and again after final assembly. Tailoring shall be neat, trim and performed in a professional manner.
- Manufacturer to clearly mark each carton with item ID and specification number.
- Manufacturer to verify all necessary parts, hardware with each item.

Project Name: Home2 FF&E Specifications
 Scheme: B-Dynamic
 Issue Date: March-23
 Revisions: May-23 Δ1

Item Number: **(B) OF-712**
 Item Name: Counter Height Table @ Grilling Patio
 Area Name: Outdoor - Grilling Patio

Manufacturer: **Walter's Wicker**
 Address: 120 North Street
 Teterboro, NJ 07608
 Phone: 201-286-9878
 Contact: Adam Schindler
 E-mail: home2@walterswicker.com
 Web: www.walterswicker.com

Description: Counter Height Table at Grilling Patio
 Model Name/No.: WEC-FUL20010
 Width: 72"
 Depth: 30"
 Height: 35"
 Top Material/Finish: Powder coated aluminum, M2 Matte Ebony
 Base Material/Finish: Powder coated aluminum, M31 Polished Silver
 Notes: For coastal and high wind conditions, all outdoor furniture must be weighted accordingly.

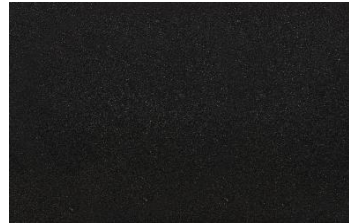
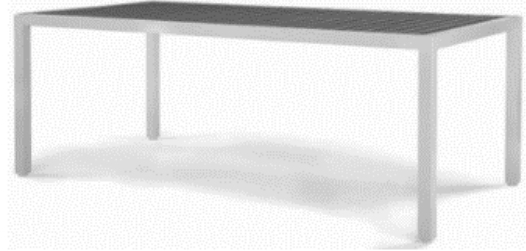

Top Finish

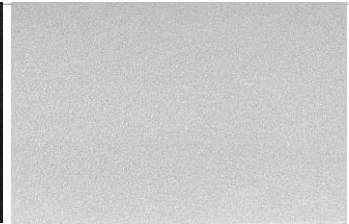

Base Finish

Unless Using A Specified Manufacturer, Submit The Following Required Item(s) for Approval Prior to Fabrication:

Finish Sample **Shop Drawing**

Manufacturer to confirm the Product meets Hilton Design and Construction Standards as noted in Section 2515.00

Instructions:

- All quantities to be verified by hotel operator prior to purchasing.
- It is the responsibility of the owner to interpret these specifications for each property.
- All interpretations of the specification MUST be submitted to Hilton Design Review (projecthub.hilton.com) for final approval prior to purchasing or implementation of any material.
- Must be of contract quality and suitable for commercial use.
- All materials and methods of construction must comply with all local fire and life safety codes and Brand Standards.
- Manufacturer to provide all necessary hardware for each item. All internal hardware (hinges, screws, bolts, etc.) shall be corrosion proof.
- Major joints as needed shall utilize lap joints or double doweled construction with corner blocks. Glue and staples are used to reinforce the joinery.
- Metal fasteners should be used where appropriate to ensure commercial frame strength.
- Manufacturer to verify all necessary parts, hardware and dimensions required for assembly.
- All wood to be kiln dried and treated to be insect and vermin free.
- Ensure that all pieces will fit in elevators and through doors prior to commencing fabrication.
- Show all pieces in shop drawings. Provide reproducible scaled shop drawings to Hotel Operator Representative prior to production.



Project Name: Home2 FF&E Specifications
Scheme: B-Dynamic
Issue Date: March-23
Revisions: May-23 Δ1

Item Number: **(B) OF-712**
Item Name: Counter Height Table @ Grilling
Patio
Area Name: Outdoor - Grilling Patio

- Provide clear alcohol and water-resistant penetrating sealer as required at wood.
- Solid hardwood frames to be certified sustainable sources. All stress joints to be connected by double doweled, screwed and glued corner reinforcement.
- All corners of metal frame to be mitered; All welds to be filled and fully finished; Grind and smooth all edges; No visible welds, seams, or burn marks; Seal as required.
- Finish goods containing composite wood products must comply with California Code of Regulations 93120. Product and carton will be labeled in accordance with this regulation.
- Manufacturer to clearly mark each carton with item ID and specification number.

Project Name: Home2 FF&E Specifications
 Scheme: B-Dynamic
 Issue Date: March-23
 Revisions: May-23 Δ1

Item Number: **(B) OF -713**
 Item Name: Chaise Lounge @ Pool
 Area Name: Pool

Manufacturer: **Tropitone**
 Address: 5 Marconi5 Marconi
 Irvine, CA 92618
 Phone: 770-831-5831
 Contact: Jeff Howe
 E-mail: jeff.howe@jhoweandassociates.com
 Web: www.tropitone.com

Description: Chaise Lounge at Pool
 Model Name/No: KOR Relaxed Armless Sling Chaise Lounge 891533
 Material/Finish: Frame: Powder Coated Aluminum, color Obsidian
 OBS
 Mesh: 89025 Cloud
 Overall Dimension: 28.5"W x 78.5"D x 15.25"H, Upright Height: 42"
 Arm Height: 19.75"
 Seat Height: 15.25"
 Seat Depth: NA
 Seat Cushion Style: Mesh sling
 Back Cushion Style: Mesh sling
 COM/COL: NA
 Notes: Nests in quantities of four



For coastal and high wind conditions, all outdoor furniture must be weighted accordingly.

Unless Using A Specified Manufacturer, Submit The Following Required Item(s) for Approval Prior to Fabrication:

Finish Sample **Cutting** **Shop Drawing**

Manufacturer to confirm the Product meets Hilton Design and Construction Standards as noted in Section 2515.00

Instructions:

- All quantities to be verified by hotel operator prior to purchasing.
- It is the responsibility of the owner to interpret these specifications for each property.
- All interpretations of the specification MUST be submitted to Hilton Design Review (projecthub.hilton.com) for final approval prior to purchasing or implementation of any material.
- Must be of contract quality and suitable for commercial use.
- COM quantities must be verified by fabricator prior to ordering.
- All materials and methods of construction must comply with all local fire and life safety codes for use in hotels and other public spaces, and Home2 Brand Standards.
- All internal hardware (hinges, screws, bolts, etc.) shall be corrosion proof.
- Wood frames to be certified sustainable sources. All stress joints to be connected by double doweled, screwed and glued corner reinforcement.
- Manufacturer to provide nylon carpet glides when applicable.
- All foam, batting, padding, and Dacron wrap shall be fire retardant to meet all applicable codes.
- Cushions to be adequately vented for displacement of air and to provide increased comfort.
- Ensure that upholstered goods will fit in elevators and through doors prior to commencing fabrication.
- Entire frame and upholstery shall be inspected during the manufacturing and again after final assembly. Tailoring shall be neat, trim and performed in a professional manner.



Project Name: Home2 FF&E Specifications
Scheme: B-Dynamic
Issue Date: March-23
Revisions: May-23 Δ1

Item Number: **(B) OF -713**
Item Name: Chaise Lounge @ Pool
Area Name: Pool

-
- Manufacturer to clearly mark each carton with item ID and specification number.
 - Manufacturer to verify all necessary parts, hardware with each item.

Project Name: Home2 FF&E Specifications
 Scheme: B-Dynamic
 Issue Date: March-23
 Revisions: June-23 Δ2

Item Number: **(B) OF-714**
 Item Name: Round Side Table @ Pool
 Area Name: Outdoor- Grilling Patio
 Pool Area

Manufacturer: **Tropitone**
 Address: 5 Marconi5 Marconi
 Irvine, CA 92618
 Phone: 770-831-5831
 Contact: Jeff Howe
 E-mail: jeff.howe@jhoweandassociates.com
 Web: www.tropitone.com

Description: Round Side Table at Pool
 Model Name/No.: Radius 16" Round Tea Table/3B2182
 Diameter: 16"
 Height: 18.5"
 Material/Finish: Marine-grade polymer, color Bright Red (BRD)
 Notes: For coastal and high wind conditions, all outdoor furniture must be weighted accordingly.



Unless Using A Specified Manufacturer, Submit The Following Required Item(s) for Approval Prior to Fabrication:

Finish Sample **Shop Drawing**

Manufacturer to confirm the Product meets Hilton Design and Construction Standards as noted in Section 2515.00

Instructions:

- All quantities to be verified by hotel operator prior to purchasing.
- It is the responsibility of the owner to interpret these specifications for each property.
- All interpretations of the specification MUST be submitted to Hilton Design Review (projecthub.hilton.com) for final approval prior to purchasing or implementation of any material.
- Must be of contract quality and suitable for commercial use.
- All materials and methods of construction must comply with all local fire and life safety codes and Brand Standards.
- Manufacturer to provide all necessary hardware for each item. All internal hardware (hinges, screws, bolts, etc.) shall be corrosion proof.
- Major joints as needed shall utilize lap joints or double doweled construction with corner blocks. Glue and staples are used to reinforce the joinery.
- Metal fasteners should be used where appropriate to ensure commercial frame strength.
- Manufacturer to verify all necessary parts, hardware and dimensions required for assembly.
- All wood to be kiln dried and treated to be insect and vermin free.
- Ensure that all pieces will fit in elevators and through doors prior to commencing fabrication.
- Show all pieces in shop drawings. Provide reproducible scaled shop drawings to Hotel Operator Representative prior to production.
- Provide clear alcohol and water-resistant penetrating sealer as required at wood.
- Solid hardwood frames to be certified sustainable sources. All stress joints to be connected by double doweled, screwed and glued corner reinforcement.
- All corners of metal frame to be mitered; All welds to be filled and fully finished; Grind and smooth all edges; No visible welds, seams, or burn marks; Seal as required.
- Finish goods containing composite wood products must comply with California Code of Regulations 93120. Product and carton will be labeled in accordance with this regulation.
- Manufacturer to clearly mark each carton with item ID and specification number.

Project Name: Home2 FF&E Specifications
 Scheme: B-Dynamic
 Issue Date: March-23
 Revisions: June-23 Δ2

Item Number: **(B) OF-715**
 Item Name: Round 2 Top Table @ Pool
 Area Name: Outdoor- Pool Area

Manufacturer: **Emuamericas**
 Address: 4465 Kipling St Suite 201
 Wheat Ridge, CO 80033
 Phone: 303-733-3385 x220
 Contact: Katarina Triska
 E-mail: ktriska@emuamericas.com
 Web: www.emuamericas.com

Description: Round 2 Top Table at Pool
 Model Name/No.: Bistro #900
 Diameter: 24"
 Height: 30"
 Base Diameter: 16"
 Top Thickness: 3/4"
 Top Material/Finish: Solid Steel, color 24 A/Black
 Base Material/Finish: Solid Steel, color 24 A/Black
 Notes: For coastal and high wind conditions, all outdoor furniture must be weighted accordingly.



Metal Finish

Unless Using A Specified Manufacturer, Submit The Following Required Item(s) for Approval Prior to Fabrication:

Finish Sample **Shop Drawing**

Manufacturer to confirm the Product meets Hilton Design and Construction Standards as noted in Section 2515.00

Instructions:

- All quantities to be verified by hotel operator prior to purchasing.
- It is the responsibility of the owner to interpret these specifications for each property.
- All interpretations of the specification MUST be submitted to Hilton Design Review (projecthub.hilton.com) for final approval prior to purchasing or implementation of any material.
- Must be of contract quality and suitable for commercial use.
- All materials and methods of construction must comply with all local fire and life safety codes and Brand Standards.
- Manufacturer to provide all necessary hardware for each item. All internal hardware (hinges, screws, bolts, etc.) shall be corrosion proof.
- Major joints as needed shall utilize lap joints or double doweled construction with corner blocks. Glue and staples are used to reinforce the joinery.
- Metal fasteners should be used where appropriate to ensure commercial frame strength.
- Manufacturer to verify all necessary parts, hardware and dimensions required for assembly.
- All wood to be kiln dried and treated to be insect and vermin free.
- Ensure that all pieces will fit in elevators and through doors prior to commencing fabrication.
- Show all pieces in shop drawings. Provide reproducible scaled shop drawings to Hotel Operator Representative prior to production.
- Provide clear alcohol and water-resistant penetrating sealer as required at wood.
- Solid hardwood frames to be certified sustainable sources. All stress joints to be connected by double doweled, screwed and glued corner reinforcement.
- All corners of metal frame to be mitered; All welds to be filled and fully finished; Grind and smooth all edges; No visible welds, seams, or burn marks; Seal as required.



Project Name: Home2 FF&E Specifications
Scheme: B-Dynamic
Issue Date: March-23
Revisions: June-23 Δ2

Item Number: **(B) OF-715**
Item Name: Round 2 Top Table @ Pool
Area Name: Outdoor- Pool Area

-
- Finish goods containing composite wood products must comply with California Code of Regulations 93120. Product and carton will be labeled in accordance with this regulation.
 - Manufacturer to clearly mark each carton with item ID and specification number.

Project Name:	Home2 FF&E Specifications	Item Number:	(B) OF -716
Scheme:	B-Dynamic	Item Name:	Outdoor Planter
Issue Date:	March-23		
Revisions:	June-23 Δ2	Area Name:	Outdoor - Outdoor Lounge

Manufacturer: **Walter's Wicker**
 Address: 120 North Street
 Teterboro, NJ 07608
 Phone: 201-286-9878
 Contact: Adam Schindler
 E-mail: home2@walterswicker.com
 Web: www.walterswicker.com

Description: Outdoor Planter @ Outdoor Lounge
 Model Name/No: WEC-Boca-PLT
 Material/Finish: Metal, M13 Slate Grey
 Overall Dimension: 54"W x 24"D x 24"H
 Notes: For coastal and high wind conditions, all outdoor furniture must be weighted accordingly.



Metal Finish

Unless Using A Specified Manufacturer, Submit The Following Required Item(s) for Approval Prior to Fabrication:

Finish Sample **Shop Drawing**

Manufacturer to confirm the Product meets Hilton Design and Construction Standards as noted in Section 2515.00

Instructions:

- All quantities to be verified by hotel operator prior to purchasing.
- It is the responsibility of the owner to interpret these specifications for each property.
- All interpretations of the specification MUST be submitted to Hilton Design Review (projecthub.hilton.com) for final approval prior to purchasing or implementation of any material.
- Must be of contract quality and suitable for commercial use.
- All materials and methods of construction must comply with all local fire and life safety codes and Brand Standards.
- Manufacturer to provide all necessary hardware for each item. All internal hardware (hinges, screws, bolts, etc.) shall be corrosion proof.
- Major joints as needed shall utilize lap joints or double doweled construction with corner blocks. Glue and staples are used to reinforce the joinery.
- Metal fasteners should be used where appropriate to ensure commercial frame strength.
- Manufacturer to verify all necessary parts, hardware and dimensions required for assembly.
- All wood to be kiln dried and treated to be insect and vermin free.
- Ensure that all pieces will fit in elevators and through doors prior to commencing fabrication.
- Show all pieces in shop drawings. Provide reproducible scaled shop drawings to Hotel Operator Representative prior to production.



Project Name: Home2 FF&E Specifications
Scheme: B-Dynamic
Issue Date: March-23
Revisions: June-23 Δ2

Item Number: **(B) OF -716**
Item Name: Outdoor Planter
Area Name: Outdoor - Outdoor Lounge

- Provide clear alcohol and water-resistant penetrating sealer as required at wood.
- Solid hardwood frames to be certified sustainable sources. All stress joints to be connected by double doweled, screwed and glued corner reinforcement.
- All corners of metal frame to be mitered; All welds to be filled and fully finished; Grind and smooth all edges; No visible welds, seams, or burn marks; Seal as required.
- Finish goods containing composite wood products must comply with California Code of Regulations 93120. Product and carton will be labeled in accordance with this regulation.



Project Name: Home2 Prototype FF&E Specifications
Scheme: B-Dynamic
Issue Date: March-23
Revisions: June-23 Δ2

Item Number: **(B) OF-717**
Item Name: String Lights @ Outdoor Lounge & Grilling Patio
Area Name: Outdoor - Outdoor Lounge & Grilling Patio

Manufacturer: **HD Supply**
Address:

Phone: 800-431-3002
Contact:
E-mail: sunitaben.patel2@hdsupply.co
Web: www.hdsupplysolutions.com

Description: String Lights at Outdoor, Commercial Grade, Weatherproof
Model Name/No.: Commercial Grade FEIT 30'-0" LED #S14 String Lights A1V17/SL3(15/FIL
Dimensions: 364" L x 17" H, Bulbs included
Finish: Black
Switch Type: Plug-in
Lamp Type: E26 Medium Base - 120V Amber Bulb finish
Lamp Wattage: LED - SMD/Color Tem: 2200/CRI: 80/ 15,000 hour life span
Lamp Quantity: 17 Bulbs
UL Listing: cULus Listed for Wet Locations. Fixture must be U.L. listed and so labeled
Dimmer: Non-dimming
Color Temperature: 2200K
Notes: Refer to prototype drawings for location.
15 Bulbs included, must order in multiples of (4).



Unless Using A Specified Manufacturer, Submit The Following Required Item(s) for Approval Prior to Fabrication:

Finish Sample **Shop Drawing**

Manufacturer to confirm the Product meets Hilton Design and Construction Standards as noted in Section 2515.03

Instructions:

- All quantities to be verified by hotel operator prior to purchasing.
- It is the responsibility of the owner to interpret these specifications for each property.
- All interpretations of the specification MUST be submitted to Hilton Design Review (projecthub.hilton.com) for final approval prior to purchasing or implementation of any material.
- Must be of contract quality and suitable for commercial use.
- All materials and methods of construction must comply with all local fire and life safety codes and Brand Standards.
- Fixture must be U.L. Listed and so labeled. Manufacturer is responsible for submitting all technical specifications for fire safety, UL standards, and any other specifications that are required to comply with local and state fire codes.
- Manufacturer/Fabricator to confirm weight of fixture.
- Manufacturer/Fabricator to verify installation method and hanging points.
- Show all pieces in scaled shop drawings. Entire fixture shall be inspected during the manufacturing and again after final assembly.
- Manufacturer to clearly mark each carton with item ID and specification number.



Project Name: Home2 Prototype FF&E Specifications
Scheme: B-Dynamic
Issue Date: March-23
Revisions:

Item Number: **(B) OF-717.1**
Item Name: Light Bulbs @ String Lights @
Outdoor Lounge & Grilling Patio
Area Name: Outdoor - Outdoor Lounge &
Grilling Patio

Manufacturer: **American Lighting**
Address: 11775 East 45th Avenue
Denver, CO 72956
Phone: 800-880-1180
Contact:
E-mail: sales@americanlighting.com
Web: www.americanlighting.com

Description: Light Bulbs at String Lights
Model Name/No.: Pro Dec 14 Series Decorative Lamps/PS14-E26-WW
Lamp Type: S14/E26 LED - 120V AC, 60Hz
Lamp Wattage: 1.4W
Lamp Quantity: See Notes
UL Listing: cULus Listed for Outdoor/Indoor use. Fixture must be U.L. listed
and so labeled
Color Temperature: 2700K
Notes: Sold by the case (25/ea.) See OF-717 for required bulb quantity.
Rated Life: 25,000 hours



Unless Using A Specified Manufacturer, Submit The Following Required Item(s) for Approval Prior to Fabrication:

Finish Sample **Shop Drawing**

Manufacturer to confirm the Product meets Hilton Design and Construction Standards as noted in Section 2515.03

Instructions:

- All quantities to be verified by hotel operator prior to purchasing.
- It is the responsibility of the owner to interpret these specifications for each property.
- All interpretations of the specification MUST be submitted to Hilton Design Review (projecthub.hilton.com) for final approval prior to purchasing or implementation of any material.
- Must be of contract quality and suitable for commercial use.
- All materials and methods of construction must comply with all local fire and life safety codes and Brand Standards.
- Fixture must be U.L. Listed and so labeled. Manufacturer is responsible for submitting all technical specifications for fire safety, UL standards, and any other specifications that are required to comply with local and state fire codes.
- Manufacturer/Fabricator to confirm weight of fixture.
- Manufacturer/Fabricator to verify installation method and hanging points.
- Show all pieces in scaled shop drawings. Entire fixture shall be inspected during the manufacturing and again after final assembly.
- Manufacturer to clearly mark each carton with item ID and specification number.

Project Name: Home2 Prototype FF&E Specifications
 Scheme: B-Dynamic
 Issue Date: May-23
 Revisions:

Item Number: **(B) OF-718**
 Item Name: Bench Seating @ Grilling Patio
 Area Name: Outdoor- Grilling Patio

Manufacturer: **Walter's Wicker**
 Address: 120 North Street
 Teterboro, NJ 07608
 Phone: 201-286-9878
 Contact: Adam Schindler
 E-mail: home2@walterswicker.com
 Web: www.walterswicker.com

Description: Rectangular Bench with Cushions at Grilling Patio
 Composed of Two 72" Benches



Model Name/No.: WE-BOCA-43092
 Material/Finish: Powder coated aluminum frame M2 Matte Ebony
 Overall Dimension: Grilling Patio: 144" W x 32"D x 30"H
 Seat Height: 18"

Seat Cushion Style: Attached and removable
 Back Cushion Style: Attached and removable
 Cushion Content: All foam, filling and water resistant muslin wrap shall be fire retardant to meet all applicable codes. Must pass NFPA 260 / CAL 117.

COM/COL: Manufacturer: Giati
 Pattern: Writer's Retreat
 Color: Ash #9053
 Finish: Teflon
 Fire Rating: CAL117-2013, NFPA 260
 Content: 100% Solution Dyed Acrylic
 Width: 60"
 Repeat: NA
 Double Rubs: 20,000
 Backing: None
 Railroad: No

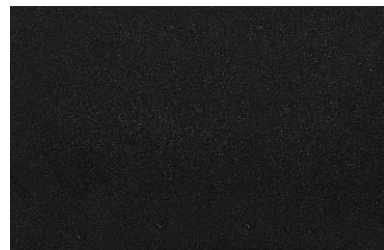

Metal Finish

Notes: For coastal and high wind conditions, all outdoor furniture must be weighted accordingly.

Unless Using A Specified Manufacturer, Submit The Following Required Item(s) for Approval Prior to Fabrication:

Finish Sample **Cutting** **Shop Drawing**

Manufacturer to confirm the Product meets Hilton Design and Construction Standards as noted in Section 2515.00

Instructions:

- All quantities to be verified by hotel operator prior to purchasing.
- It is the responsibility of the owner to interpret these specifications for each property.
- All interpretations of the specification MUST be submitted to Hilton Design Review (projecthub.hilton.com) for final approval prior to purchasing or implementation of any material.
- Must be of contract quality and suitable for commercial use.
- COM quantities must be verified by fabricator prior to ordering.
- All materials and methods of construction must comply with all local fire and life safety codes for use in hotels and other public spaces, and Home2 Brand Standards.
- All internal hardware (hinges, screws, bolts, etc.) shall be corrosion proof.
- Wood frames to be certified sustainable sources. All stress joints to be connected by double doweled, screwed and glued corner reinforcement.



Project Name: Home2 Prototype FF&E Specifications

Item Number: **(B) OF-718**

Scheme: B-Dynamic

Item Name: Bench Seating @ Grilling Patio

Issue Date: May-23

Revisions:

Area Name: Outdoor- Grilling Patio

- Manufacturer to provide nylon carpet glides when applicable.
- All foam, batting, padding, and Dacron wrap shall be fire retardant to meet all applicable codes.
- Cushions to be adequately vented for displacement of air and to provide increased comfort.
- Ensure that upholstered goods will fit in elevators and through doors prior to commencing fabrication.
- Entire frame and upholstery shall be inspected during the manufacturing and again after final assembly. Tailoring shall be neat, trim and performed in a professional manner.
- Manufacturer to clearly mark each carton with item ID and specification number.
- Manufacturer to verify all necessary parts, hardware with each item.

Project Name: Home2 FF&E Specifications
Scheme: B-Dynamic
Issue Date: June-23

Item Number: **(B) OF-719**
Item Name: 4 Top ADA Dining Table @ Pool
Area Name: Outdoor- Pool Area

Revisions:

Manufacturer: **Emuamericas**
Address: 4465 Kipling St Suite 201
Wheat Ridge, CO 80033
Phone: 303-733-3385 x220
Contact: Katarina Triska
E-mail: ktriska@emuamericas.com
Web: www.emuamericas.com

Description: Square Metal Dining Table at Pool with Umbrella Hole

Model Name/No.: Nova #859WH

Width: 36"

Depth: 36"

Height: 29"

Top Material/Finish: Solid Steel, color 24 A/Black

Base Material/Finish: Solid Steel, color 24 A/Black

Notes: Table is ONLY ADA compliant when used without an umbrella.

Table meets ADA requirements, with knee space of at least 27"Hm
30"W and 19"D,

Dining table is self leveling.

For coastal and high wind conditions, all outdoor furniture must be weighted accordingly.



Metal Finish



Unless Using A Specified Manufacturer, Submit The Following Required Item(s) for Approval Prior to Fabrication:

Finish Sample **Shop Drawing**

Manufacturer to confirm the Product meets Hilton Design and Construction Standards as noted in Section 2515.00

Instructions:

- All quantities to be verified by hotel operator prior to purchasing.
- It is the responsibility of the owner to interpret these specifications for each property.
- All interpretations of the specification MUST be submitted to Hilton Design Review (projecthub.hilton.com) for final approval prior to purchasing or implementation of any material.
- Must be of contract quality and suitable for commercial use.
- All materials and methods of construction must comply with all local fire and life safety codes and Brand Standards.
- Manufacturer to provide all necessary hardware for each item. All internal hardware (hinges, screws, bolts, etc.) shall be corrosion proof.
- Major joints as needed shall utilize lap joints or double doweled construction with corner blocks. Glue and staples are used to reinforce the joinery.
- Metal fasteners should be used where appropriate to ensure commercial frame strength.
- Manufacturer to verify all necessary parts, hardware and dimensions required for assembly.
- All wood to be kiln dried and treated to be insect and vermin free.
- Ensure that all pieces will fit in elevators and through doors prior to commencing fabrication.
- Show all pieces in shop drawings. Provide reproducible scaled shop drawings to Hotel Operator Representative prior to production.
- Provide clear alcohol and water-resistant penetrating sealer as required at wood.



Project Name: Home2 FF&E Specifications
Scheme: B-Dynamic
Issue Date: June-23

Item Number: **(B) OF-719**
Item Name: 4 Top ADA Dining Table @ Pool
Area Name: Outdoor- Pool Area

Revisions:

- Solid hardwood frames to be certified sustainable sources. All stress joints to be connected by double doweled, screwed and glued corner reinforcement.
- All corners of metal frame to be mitered; All welds to be filled and fully finished; Grind and smooth all edges; No visible welds, seams, or burn marks; Seal as required.
- Finish goods containing composite wood products must comply with California Code of Regulations 93120. Product and carton will be labeled in accordance with this regulation.
- Manufacturer to clearly mark each carton with item ID and specification number.

Project Name: Home2 Prototype FF&E Specifications
 Scheme: B-Dynamic
 Issue Date: March-23

Item Number: **(B) PA-800**
 Item Name: Perch Table
 Area Name: Public Area - Lobby

Revisions:

Manufacturer: **Elkay Interior Systems**
 Address: 1 Mid America Plaza, Floor 3
 Oakbrook Terrace, IL 60181
 Phone: 414-224-0957
 Contact: Courtney Messersmith
 E-mail: hospitalitybids@elkayinteriorsystems.com
 Web: www.elkayinteriorsystems.com

Description: Counter-height Window Perch @ Lobby
 Style: Window perch with HPL top with PVC edge banding and steel supports (34" H counter to meet ADA Guideline Standards)

Width: 197"
 Depth: 21"
 Height: 34"

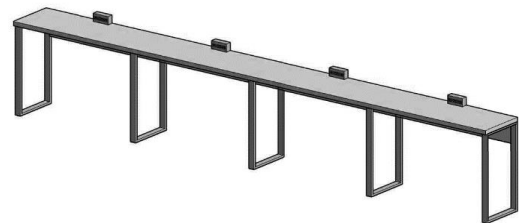

Top Material/Finish: Plastic Laminate, Finish to match PL-01 Wilsonart 5th Ave Elm 7966K-12 Soft Grain Texture with Aeon

Edge Detail: 2 mm edgebanding to match PL-01 Wilsonart 5th Ave Elm 7966K-12 Soft Grain Texture with Aeon

Base Material/Finish: Steel, powder-coated to match TIGER Drylac Sparkle Silver Glossy 49/90450

Wire Manager: Z Clips: Doug Mockett VM28/2IN-90

Power Supply: 4 each Byrne Electrical Burele (or equal) with 2 outlets and 2 sets of charging USB, black finish - 15-0" power cord

Notes: Manufacturer to verify size requirements by on-site measurements taken prior to fabrication.

Manufacturer to provide template to coordinate fabrication of top and base. All pieces to be mechanically secured together. Provide all corrosion proof hardware to secure pieces together.

Provide heavy duty adjustable nylon glides.



PL-01



Metal Finish

Unless Using A Specified Manufacturer, Submit The Following Required Item(s) for Approval Prior to Fabrication:

Finish Sample **Shop Drawing**

Manufacturer to confirm the Product meets Hilton Design and Construction Standards as noted in Section 2515.00

Instructions:

- All quantities to be verified by hotel operator prior to purchasing.
- It is the responsibility of the owner to interpret these specifications for each property.
- All interpretations of the specification MUST be submitted to Hilton Design Review (projecthub.hilton.com) for final approval prior to purchasing or implementation of any material.
- Must be of contract quality and suitable for commercial use.
- All materials and methods of construction must comply with all local fire and life safety codes and Brand Standards.
- Manufacturer to provide all necessary hardware for each item. All internal hardware (hinges, screws, bolts, etc.) shall be corrosion proof.



Project Name: Home2 Prototype FF&E Specifications
Scheme: B-Dynamic
Issue Date: March-23

Item Number: **(B) PA-800**
Item Name: Perch Table
Area Name: Public Area - Lobby

Revisions:

- Major joints as needed shall utilize lap joints or double doweled construction with corner blocks. Glue and staples are used to reinforce the joinery.
- Metal fasteners should be used where appropriate to ensure commercial frame strength.
- Manufacturer to verify all necessary parts, hardware and dimensions required for assembly.
- All wood to be kiln dried and treated to be insect and vermin free.
- Ensure that all pieces will fit in elevators and through doors prior to commencing fabrication.
- Show all pieces in shop drawings. Provide reproducible scaled shop drawings to Hotel Operator Representative prior to production.
- Provide clear alcohol and water-resistant penetrating sealer as required at wood.
- Solid hardwood frames to be certified sustainable sources. All stress joints to be connected by double doweled, screwed and glued corner reinforcement.
- All corners of metal frame to be mitered; All welds to be filled and fully finished; Grind and smooth all edges; No visible welds, seams, or burn marks; Seal as required.
- Finish goods containing composite wood products must comply with California Code of Regulations 93120. Product and carton will be labeled in accordance with this regulation.
- Manufacturer to clearly mark each carton with item ID and specification number.

Project Name: Home2 Prototype FF&E Specifications
 Scheme: B-Dynamic
 Issue Date: March-23
 Revisions:

Item Number: **(B) PA-801**
 Item Name: Reception Desk
 Area Name: Public Area - Lobby

Manufacturer: **Elkay Interior Systems**
 Address: 1 Mid America Plaza, Floor 3
 Oakbrook Terrace, IL 60181
 Phone: 414-224-0957
 Contact: Courtney Messersmith
 E-mail: hospitalitybids@elkayinteriorsystems.com
 Web: www.elkayinteriorsystems.com

Description: Reception Desk @ Lobby
 Style: Registration desk with integrated power, storage, guest and employee counter space, maple dovetail drawers, and 34"H counter to meet ADA Guideline Standards

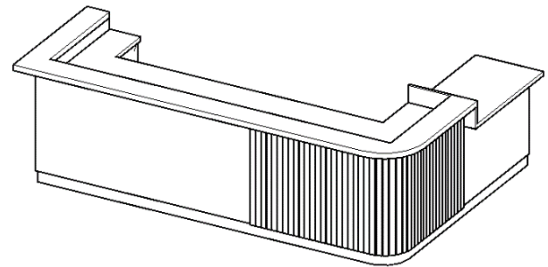

Dimensions: 138"W x 90"D x 42"H, 34"H ADA counter
 Finish: Top Finish to match ST-01 Daltile One Quartz - Simply White Polished with square, eased edges.
 Main Plastic Laminate Finish to match PL-01 Wilsonart 5th Ave Elm 7966K-12 Soft Grain Texture with Aeon.
 Accent Plastic Laminate, Finish to match PL-02 Wilsonart High Line 7970K-18 Linearity Finish with Aeon
 Hardware: Pulls: Berenson 6131-2SC-P
 Finish: To match TIGER Drylac Sparkle Silver Glossy 49/90450
 Dimensions: 4-1/16"W x 1-1/4"D x 5/16"H
 Note: Pulls must be ADA compliant



ST-01



PL-01



PL-02



Hardware Finish

Hinges: Blum BP71T5690/BP173H9130
 Glides: Knap & Vogt 8450
 Grommets - Doug Mockett MG3-94
 Shelf Pins: Progressive IF739NP
 Locks: NLC 8173 deadbolt (cash drawers keyed separately)
 Hanging File Hardware
 Fan: Comair Rotran WRZA1/Grainger Stock 5C153

Data/Electrical: NA

Notes: Manufacturer to verify size requirements by on-site measurements taken prior to fabrication.
 Manufacturer to provide template to coordinate fabrication of top and base. All pieces to be mechanically secured together. Provide all corrosion proof hardware to secure pieces together.
 Manufacturer to provide adequate ventilation and air circulation to house computer equipment.
 Provide 1.5" (40mm) diameter holes for cords.
 Provide one pair side-mounted, ball bearing action, full extension drawer glides (accuride or equal) per drawer/tray.
 Provide heavy-duty adjustable levelers.
 All cabinets and drawers to have same keyed locks.



Project Name: Home2 Prototype FF&E Specifications
Scheme: B-Dynamic
Issue Date: March-23

Item Number: **(B) PA-801**
Item Name: Reception Desk
Area Name: Public Area - Lobby

Revisions:

Unless Using A Specified Manufacturer, Submit The Following Required Item(s) for Approval Prior to Fabrication:

Finish Sample **Shop Drawing**

Manufacturer to confirm the Product meets Hilton Design and Construction Standards as noted in Section 2515.00

Instructions:

- All quantities to be verified by hotel operator prior to purchasing.
- It is the responsibility of the owner to interpret these specifications for each property.
- All interpretations of the specification MUST be submitted to Hilton Design Review (projecthub.hilton.com) for final approval prior to purchasing or implementation of any material.
- Must be of contract quality and suitable for commercial use.
- All materials and methods of construction must comply with all local fire and life safety codes and Brand Standards.
- Manufacturer to provide all necessary hardware for each item. All internal hardware (hinges, screws, bolts, etc.) shall be corrosion proof.
- Major joints as needed shall utilize lap joints or double doweled construction with corner blocks. Glue and staples are used to reinforce the joinery.
- Metal fasteners should be used where appropriate to ensure commercial frame strength.
- Manufacturer to verify all necessary parts, hardware and dimensions required for assembly.
- All wood to be kiln dried and treated to be insect and vermin free.
- Ensure that all pieces will fit in elevators and through doors prior to commencing fabrication.
- Show all pieces in shop drawings. Provide reproducible scaled shop drawings to Hotel Operator Representative prior to production.
- Provide clear alcohol and water-resistant penetrating sealer as required at wood.
- Solid hardwood frames to be certified sustainable sources. All stress joints to be connected by double doweled, screwed and glued corner reinforcement.
- All corners of metal frame to be mitered; All welds to be filled and fully finished; Grind and smooth all edges; No visible welds, seams, or burn marks; Seal as required.
- Finish goods containing composite wood products must comply with California Code of Regulations 93120. Product and carton will be labeled in accordance with this regulation.
- Manufacturer to clearly mark each carton with item ID and specification number.

Project Name: Home2 Prototype FF&E Specifications
 Scheme: B-Dynamic
 Issue Date: March-23

Item Number: **(B) PA-802**
 Item Name: Breakfast Servery
 Area Name: Public Area - Breakfast

Revisions:

Manufacturer: **Elkay Interior Systems**
 Address: 1 Mid America Plaza, Floor 3
 Oakbrook Terrace, IL 60181
 Phone: 414-224-0957
 Contact: Courtney Messersmith
 E-mail: hospitalitybids@elkayinteriorsystems.com
 Web: www.elkayinteriorsystems.com

Description: Breakfast Servery @ Breakfast
 Style: Serving counters with base cabinets, integrated openings for equipment and overhead storage. All upper cabinet faces to receive F&B graphics.
 Dimensions: Large Servery: 245"W x 36"D x 98"H, Small servery: 96"W x 31" D x 34"H, 63" to top of Yogurt Machine hutch
 Verify all dimensions in field prior to fabrication
 Top Material/Finish: Quartz top, Finish to match ST-01 Daltile One Quartz - Simply White Polished with square, eased edges.

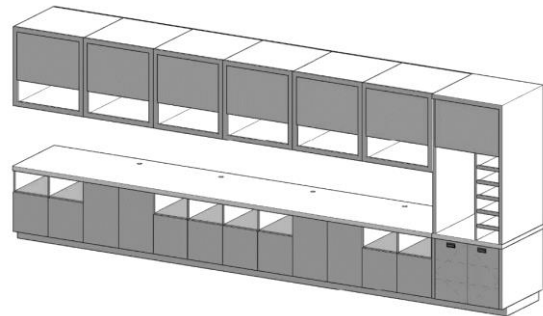

Base Material/Finish: Plastic Laminate, Finish to match PL-01 Wilsonart 5th Ave Elm 7966K-12 Soft Grain Texture with Aeon
 Hardware: Pulls: Manzoni Hardware #MT0337-203-GSN (Satin Nickel) or approved eq.
 Finish: To match TIGER Drylac Sparkle Silver Glossy 49/90450
 Dimensions: 8 3/4"L x 1-1/8"D x 3/8"W
 Note: Pulls must be ADA compliant

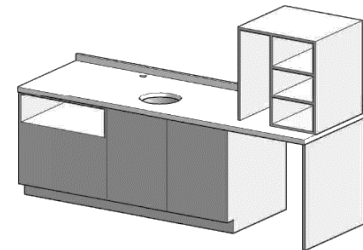

Hinges: Blum BP71T5690/BP173H9130
 Shelf Pins: Progressive IF739NP

Data/Electrical: NA

Notes: Manufacturer to verify size requirements by on-site measurements taken prior to fabrication.

Manufacturer to provide template to coordinate fabrication of top and base. All pieces to be mechanically secured together. Provide all corrosion proof hardware to secure pieces together.

Manufacturer to provide adequate ventilation and air circulation to house juice machine.

Provide 1.5" (40mm) diameter holes for cords.

Provide one pair side-mounted, ball bearing action, full extension drawer glides (accuride or equal) per drawer/tray.

Provide heavy-duty adjustable levelers.

All cabinets and drawers to have same keyed locks.



ST-01



PL-01



Hardware Finish



Project Name: Home2 Prototype FF&E Specifications

Item Number: **(B) PA-802**

Scheme: B-Dynamic

Item Name: Breakfast Servery

Issue Date: March-23

Area Name: Public Area - Breakfast

Revisions:

Unless Using A Specified Manufacturer, Submit The Following Required Item(s) for Approval Prior to Fabrication:

Finish Sample **Shop Drawing**

Manufacturer to confirm the Product meets Hilton Design and Construction Standards as noted in Section 2515.00

Instructions:

- All quantities to be verified by hotel operator prior to purchasing.
- It is the responsibility of the owner to interpret these specifications for each property.
- All interpretations of the specification MUST be submitted to Hilton Design Review (projecthub.hilton.com) for final approval prior to purchasing or implementation of any material.
- Must be of contract quality and suitable for commercial use.
- All materials and methods of construction must comply with all local fire and life safety codes and Brand Standards.
- Manufacturer to provide all necessary hardware for each item. All internal hardware (hinges, screws, bolts, etc.) shall be corrosion proof.
- Major joints as needed shall utilize lap joints or double doweled construction with corner blocks. Glue and staples are used to reinforce the joinery.
- Metal fasteners should be used where appropriate to ensure commercial frame strength.
- Manufacturer to verify all necessary parts, hardware and dimensions required for assembly.
- All wood to be kiln dried and treated to be insect and vermin free.
- Ensure that all pieces will fit in elevators and through doors prior to commencing fabrication.
- Show all pieces in shop drawings. Provide reproducible scaled shop drawings to Hotel Operator Representative prior to production.
- Provide clear alcohol and water-resistant penetrating sealer as required at wood.
- Solid hardwood frames to be certified sustainable sources. All stress joints to be connected by double doweled, screwed and glued corner reinforcement.
- All corners of metal frame to be mitered; All welds to be filled and fully finished; Grind and smooth all edges; No visible welds, seams, or burn marks; Seal as required.
- Finish goods containing composite wood products must comply with California Code of Regulations 93120. Product and carton will be labeled in accordance with this regulation.
- Manufacturer to clearly mark each carton with item ID and specification number.

Project Name: Home2 Prototype FF&E Specifications
 Scheme: B-Dynamic
 Issue Date: March-23
 Revisions:

Item Number: **(B) PA-803**
 Item Name: Coffee & Hydration Station
 Area Name: Public Area - Lobby

Manufacturer: **Elkay Interior Systems**
 Address: 1 Mid America Plaza, Floor 3
 Oakbrook Terrace, IL 60181
 Phone: 414-224-0957
 Contact: Courtney Messersmith
 E-mail: hospitalitybids@elkayinteriorsystems.com
 Web: www.elkayinteriorsystems.com

Description: Coffee and Hydration Station @ Lobby
 Style: Coffee, tea, and water faucet with integrated storage cabinets, printer and trash.
 Dimensions: 138"W x 90"D x 42"H, 34"H ADA counter
 Top Material/Finish: Quartz top, Finish to match ST-01 Daltile One Quartz - Simply White Polished with square, eased edges.

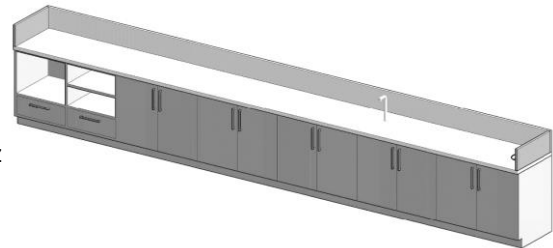

Base Material/Finish: Plastic Laminate, Finish to match PL-01 Wilsonart 5th Ave Elm 7966K-12 Soft Grain Texture with Aeon

Hardware: Pulls: Manzoni Hardware #MT0337-203-GSN (Satin Nickel) or approved eq.
 Finish: To match TIGER Drylac Sparkle Silver Glossy 49/90450
 Dimensions: 8 3/4"L x 1-1/8"D x 3/8"W
 Note: Pulls must be ADA compliant



ST-01

Hinges: Blum BP71T5690/BP173H9130
 Glides: Knappe & Vogt 8450
 Trash Grommet - Doug Mockett TM2B
 Shelf Pins: Progressive IF739NP



PL-01

Data/Electrical: NA

Notes: Manufacturer to verify size requirements by on-site measurements taken prior to fabrication.
 Manufacturer to provide template to coordinate fabrication of top and base. All pieces to be mechanically secured together. Provide all corrosion proof hardware to secure pieces together.
 Manufacturer to provide adequate ventilation and air circulation to house hydration station equipment.
 Provide one pair side-mounted, ball bearing action, full extension drawer glides (accuride or equal) per drawer/tray.
 Provide heavy-duty adjustable levelers.
 All cabinets and drawers to have same keyed locks.



Hardware Finish

Unless Using A Specified Manufacturer, Submit The Following Required Item(s) for Approval Prior to Fabrication:

Finish Sample **Shop Drawing**

Manufacturer to confirm the Product meets Hilton Design and Construction Standards as noted in Section 2515.00



Project Name: Home2 Prototype FF&E Specifications
Scheme: B-Dynamic
Issue Date: March-23

Item Number: **(B) PA-803**
Item Name: Coffee & Hydration Station
Area Name: Public Area - Lobby

Revisions:

Instructions:

- All quantities to be verified by hotel operator prior to purchasing.
- It is the responsibility of the owner to interpret these specifications for each property.
- All interpretations of the specification **MUST** be submitted to Hilton Design Review (projecthub.hilton.com) for final approval prior to purchasing or implementation of any material.
- Must be of contract quality and suitable for commercial use.
- All materials and methods of construction must comply with all local fire and life safety codes and Brand Standards.
- Manufacturer to provide all necessary hardware for each item. All internal hardware (hinges, screws, bolts, etc.) shall be corrosion proof.
- Major joints as needed shall utilize lap joints or double doweled construction with corner blocks. Glue and staples are used to reinforce the joinery.
- Metal fasteners should be used where appropriate to ensure commercial frame strength.
- Manufacturer to verify all necessary parts, hardware and dimensions required for assembly.
- All wood to be kiln dried and treated to be insect and vermin free.
- Ensure that all pieces will fit in elevators and through doors prior to commencing fabrication.
- Show all pieces in shop drawings. Provide reproducible scaled shop drawings to Hotel Operator Representative prior to production.
- Provide clear alcohol and water-resistant penetrating sealer as required at wood.
- Solid hardwood frames to be certified sustainable sources. All stress joints to be connected by double doweled, screwed and glued corner reinforcement.
- All corners of metal frame to be mitered; All welds to be filled and fully finished; Grind and smooth all edges; No visible welds, seams, or burn marks; Seal as required.
- Finish goods containing composite wood products must comply with California Code of Regulations 93120. Product and carton will be labeled in accordance with this regulation.
- Manufacturer to clearly mark each carton with item ID and specification number.

Project Name: Home2 Prototype FF&E Specifications
 Scheme: B-Dynamic
 Issue Date: March-23

Item Number: **(B) PA-804**
 Item Name: Trash & Recycling
 Area Name: Public Area - Lobby

Revisions:

Manufacturer: **Elkay Interior Systems**
 Address: 1 Mid America Plaza, Floor 3
 Oakbrook Terrace, IL 60181
 Phone: 414-224-0957
 Contact: Courtney Messersmith
 E-mail: hospitalitybids@elkayinteriorsystems.com
 Web: www.elkayinteriorsystems.com

Description: Trash and Recycling at Lobby
 Style: Cabinet with two cutouts in work surface for trash and recycling.
 Dimensions: 54"W x 24"D x 45"H, 34"H ADA counter
 Top Material/Finish: Quartz top, Finish to match ST-01 Daltile One Quartz - Simply White Polished with square, eased edges.
 Base Material/Finish: Plastic Laminate, Finish to match PL-01 Wilsonart 5th Ave Elm 7966K-12 Soft Grain Texture with Aeon
 Hardware: Pulls: Manzoni Hardware #MT0337-203-GSN (Satin Nickel) or approved eq.
 Finish: To match TIGER Drylac Sparkle Silver Glossy 49/90450
 Dimensions: 8 3/4"L x 1-1/8"D x 3/8"W
 Note: Pulls must be ADA compliant
 Hinges: Blum BP71T5690/BP173H9130
 Glides: Knappe & Vogt 8450
 Trash Grommet - 8" Doug Mockett TM2B, 6" Doug Mockett TM1B
 Shelf Pins: Progressive IF739NP
 Data/Electrical: NA
 Notes: Manufacturer to verify size requirements by on-site measurements taken prior to fabrication.
 Manufacturer to provide template to coordinate fabrication of top and base. All pieces to be mechanically secured together. Provide all corrosion proof hardware to secure pieces together.
 Provide one pair side-mounted, ball bearing action, full extension drawer glides (accuride or equal) per drawer/tray.
 Provide heavy-duty adjustable levelers.
 All cabinets and drawers to have same keyed locks.

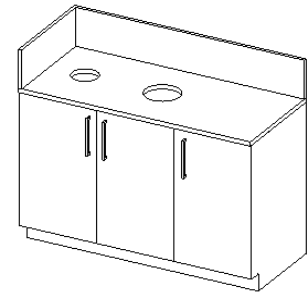

ST-01



PL-01



Hardware Finish

Unless Using A Specified Manufacturer, Submit The Following Required Item(s) for Approval Prior to Fabrication:

Finish Sample **Shop Drawing**

Manufacturer to confirm the Product meets Hilton Design and Construction Standards as noted in Section 2515.00

Instructions:

- All quantities to be verified by hotel operator prior to purchasing.
- It is the responsibility of the owner to interpret these specifications for each property.
- All interpretations of the specification MUST be submitted to Hilton Design Review (projecthub.hilton.com) for final approval prior to purchasing or implementation of any material.



Project Name: Home2 Prototype FF&E Specifications
Scheme: B-Dynamic
Issue Date: March-23

Item Number: **(B) PA-804**
Item Name: Trash & Recycling
Area Name: Public Area - Lobby

Revisions:

- Must be of contract quality and suitable for commercial use.
- All materials and methods of construction must comply with all local fire and life safety codes and Brand Standards.
- Manufacturer to provide all necessary hardware for each item. All internal hardware (hinges, screws, bolts, etc.) shall be corrosion proof.
- Major joints as needed shall utilize lap joints or double doweled construction with corner blocks. Glue and staples are used to reinforce the joinery.
- Metal fasteners should be used where appropriate to ensure commercial frame strength.
- Manufacturer to verify all necessary parts, hardware and dimensions required for assembly.
- All wood to be kiln dried and treated to be insect and vermin free.
- Ensure that all pieces will fit in elevators and through doors prior to commencing fabrication.
- Show all pieces in shop drawings. Provide reproducible scaled shop drawings to Hotel Operator Representative prior to production.
- Provide clear alcohol and water-resistant penetrating sealer as required at wood.
- Solid hardwood frames to be certified sustainable sources. All stress joints to be connected by double doweled, screwed and glued corner reinforcement.
- All corners of metal frame to be mitered; All welds to be filled and fully finished; Grind and smooth all edges; No visible welds, seams, or burn marks; Seal as required.
- Finish goods containing composite wood products must comply with California Code of Regulations 93120. Product and carton will be labeled in accordance with this regulation.
- Manufacturer to clearly mark each carton with item ID and specification number.

Project Name: Home2 Prototype FF&E Specifications
 Scheme: B-Dynamic
 Issue Date: March-23

Item Number: **(B) PA-805**
 Item Name: Guest Laundry Table
 Area Name: Public Area - Laundry Room

Revisions:

Manufacturer: **Elkay Interior Systems**
 Address: 1 Mid America Plaza, Floor 3
 Oakbrook Terrace, IL 60181

Phone: 414-224-0957
 Contact: Courtney Messersmith
 E-mail: hospitalitybids@elkayinteriorsystems.com
 Web: www.elkayinteriorsystems.com

Description: Guest Laundry Table @ Guest Laundry
 Style: Counter with two shelves with metal rods for hanging clothes
 Dimensions: Large Shelf: 66"W x 15"D x 6 3/4"H
 Small Shelf: 24"W x 15"D x 6 3/4"H
 Counter: 48"W x 20"D x 34"H
 Material/Finish: Plastic Laminate, match PL-01 Wilsonart 5th Ave Elm 7966K-12 Soft Grain Texture with Aeon, Square, eased edge with 2 mm PVC Edgebanding to match laminate.
 Stainless steel metal counter support, powder coat finish to match RAL9010
 Hardware: Rod: Knappe & Vogt KV2 ZC 30 Series Commercial Adjustable closet rod, zinc finish
 Notes: Manufacturer to verify size requirements by on-site measurements taken prior to fabrication.
 All pieces to be mechanically secured together. Provide all corrosion proof hardware to secure pieces together.
 Manufacturer to provide all required mounting hardware.

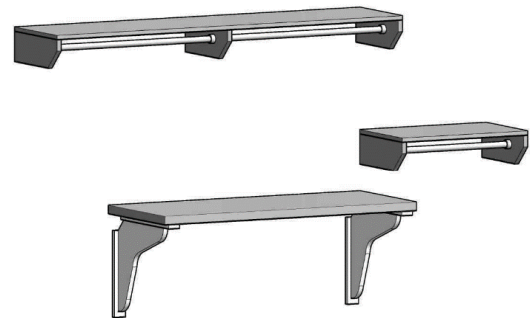

PL-01

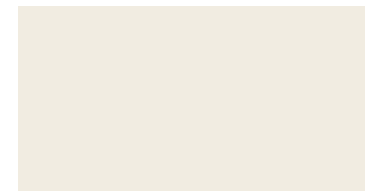

Metal Finish

Unless Using A Specified Manufacturer, Submit The Following Required Item(s) for Approval Prior to Fabrication:
Finish Sample **Shop Drawing**

Manufacturer to confirm the Product meets Hilton Design and Construction Standards as noted in Section 2515.00

Instructions:

- All quantities to be verified by hotel operator prior to purchasing.
- It is the responsibility of the owner to interpret these specifications for each property.
- All interpretations of the specification MUST be submitted to Hilton Design Review (projecthub.hilton.com) for final approval prior to purchasing or implementation of any material.
- Must be of contract quality and suitable for commercial use.
- All materials and methods of construction must comply with all local fire and life safety codes and Brand Standards.
- Manufacturer to provide all necessary hardware for each item. All internal hardware (hinges, screws, bolts, etc.) shall be corrosion proof.



Project Name: Home2 Prototype FF&E Specifications
Scheme: B-Dynamic
Issue Date: March-23

Item Number: **(B) PA-805**
Item Name: Guest Laundry Table
Area Name: Public Area - Laundry Room

Revisions:

- Major joints as needed shall utilize lap joints or double doweled construction with corner blocks. Glue and staples are used to reinforce the joinery.
- Metal fasteners should be used where appropriate to ensure commercial frame strength.
- Manufacturer to verify all necessary parts, hardware and dimensions required for assembly.
- All wood to be kiln dried and treated to be insect and vermin free.
- Ensure that all pieces will fit in elevators and through doors prior to commencing fabrication.
- Show all pieces in shop drawings. Provide reproducible scaled shop drawings to Hotel Operator Representative prior to production.
- Provide clear alcohol and water-resistant penetrating sealer as required at wood.
- Solid hardwood frames to be certified sustainable sources. All stress joints to be connected by double doweled, screwed and glued corner reinforcement.
- All corners of metal frame to be mitered; All welds to be filled and fully finished; Grind and smooth all edges; No visible welds, seams, or burn marks; Seal as required.
- Finish goods containing composite wood products must comply with California Code of Regulations 93120. Product and carton will be labeled in accordance with this regulation.
- Manufacturer to clearly mark each carton with item ID and specification number.

Project Name: Home2 Prototype FF&E Specifications
 Scheme: B-Dynamic
 Issue Date: March-23
 Revisions:

Item Number: **(B) PA-806**
 Item Name: One Bay Boardroom Casework
 Area Name: Public Area - Meeting Room

Manufacturer: **Elkay Interior Systems**
 Address: 1 Mid America Plaza, Floor 3
 Oakbrook Terrace, IL 60181
 Phone: 414-224-0957
 Contact: Courtney Messersmith
 E-mail: hospitalitybids@elkayinteriorsystems.com
 Web: www.elkayinteriorsystems.com

Description: Casework @ One Bay Boardroom
 Style: Built-in serving counter with undercounter storage compartments with adjustable shelves
 Dimensions: 75"W x 20"D x 34" Counter with 4" backsplash, VIF width in field
 Top Material/Finish: Quartz top, Finish to match ST-01 Daltile One Quartz - Simply White Polished with square, eased edges.

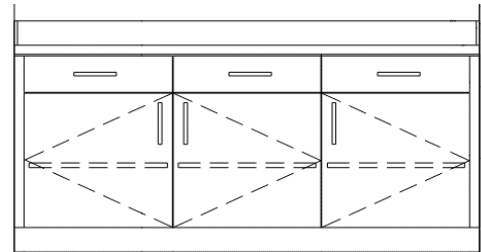

Base Material/Finish: Plastic Laminate, Finish to match PL-01 Wilsonart 5th Ave Elm 7966K-12 Soft Grain Texture with Aeon
 Hardware: Pulls: Berenson 6131-2SC-P
 Finish: To match TIGER Drylac Sparkle Silver Glossy 49/90450
 Dimensions: 4-1/16"W x 1-1/4"D x 5/16"H
 Note: Pulls must be ADA compliant



ST-01

Shelf Pins: Progressive IF739NP
 Hinges: Blum BP71T5590/BP173H9100
 Glides: Knappe & Vogt 8450
 Data/Electrical: NA



PL-01

Notes: Manufacturer to verify size requirements by on-site measurements taken prior to fabrication.
 Manufacturer to provide template to coordinate fabrication of top and base. All pieces to be mechanically secured together. Provide all corrosion proof hardware to secure pieces together.
 Provide one pair side-mounted, ball bearing action, full extension drawer glides (accuride or equal) per drawer/tray.
 Provide heavy-duty adjustable levelers.



Hardware Finish

Unless Using A Specified Manufacturer, Submit The Following Required Item(s) for Approval Prior to Fabrication:
Finish Sample **Shop Drawing**

Manufacturer to confirm the Product meets Hilton Design and Construction Standards as noted in Section 2515.00

Instructions:

- All quantities to be verified by hotel operator prior to purchasing.
- It is the responsibility of the owner to interpret these specifications for each property.
- All interpretations of the specification MUST be submitted to Hilton Design Review (projecthub.hilton.com) for final approval prior to purchasing or implementation of any material.
- Must be of contract quality and suitable for commercial use.



Project Name: Home2 Prototype FF&E Specifications
Scheme: B-Dynamic
Issue Date: March-23

Item Number: **(B) PA-806**
Item Name: One Bay Boardroom Casework
Area Name: Public Area - Meeting Room

Revisions:

- All materials and methods of construction must comply with all local fire and life safety codes and Brand Standards.
- Manufacturer to provide all necessary hardware for each item. All internal hardware (hinges, screws, bolts, etc.) shall be corrosion proof.
- Major joints as needed shall utilize lap joints or double doveled construction with corner blocks. Glue and staples are used to reinforce the joinery.
- Metal fasteners should be used where appropriate to ensure commercial frame strength.
- Manufacturer to verify all necessary parts, hardware and dimensions required for assembly.
- All wood to be kiln dried and treated to be insect and vermin free.
- Ensure that all pieces will fit in elevators and through doors prior to commencing fabrication.
- Show all pieces in shop drawings. Provide reproducible scaled shop drawings to Hotel Operator Representative prior to production.
- Provide clear alcohol and water-resistant penetrating sealer as required at wood.
- Solid hardwood frames to be certified sustainable sources. All stress joints to be connected by double doveled, screwed and glued corner reinforcement.
- All corners of metal frame to be mitered; All welds to be filled and fully finished; Grind and smooth all edges; No visible welds, seams, or burn marks; Seal as required.
- Finish goods containing composite wood products must comply with California Code of Regulations 93120. Product and carton will be labeled in accordance with this regulation.
- Manufacturer to clearly mark each carton with item ID and specification number.

Project Name: Home2 Prototype FF&E Specifications
 Scheme: B-Dynamic
 Issue Date: March-23
 Revisions:

Item Number: **(B) PA-807**
 Item Name: Three Bay Meeting Room Casework
 Area Name: Public Area - Meeting Room

Manufacturer: **Elkay Interior Systems**
 Address: 1 Mid America Plaza, Floor 3
 Oakbrook Terrace, IL 60181
 Phone: 414-224-0957
 Contact: Courtney Messersmith
 E-mail: hospitalitybids@elkayinteriorsystems.com
 Web: www.elkayinteriorsystems.com

Description: Casework @ Three Bay Meeting Room
 Style: Built-in serving counter with undercounter storage compartments with adjustable shelves
 Dimensions: 150"W x 20"D x 34" Counter with 4" backsplash, V width in field

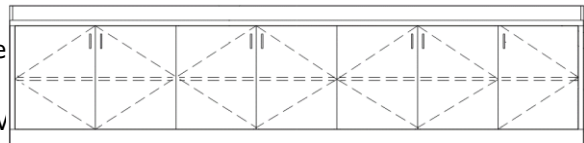

Top Material/Finish: Quartz top, Finish to match ST-01 Daltile One Quartz - Simply White Polished with square, eased edges.

Base Material/Finish: Plastic Laminate, Finish to match PL-01 Wilsonart 5th Ave Elm 7966K-12 Soft Grain Texture with Aeon

Hardware: Pulls: Berenson 6131-2SC-P
 Finish: To match TIGER Drylac Sparkle Silver Glossy 49/90450
 Dimensions: 4-1/16"W x 1-1/4"D x 5/16"H
 Note: Pulls must be ADA compliant



ST-01

Hinges: Blum BP71T5690/BP173H9130
 Shelf Pins: Progressive IF739NP

Data/Electrical: NA

Notes: Manufacturer to verify size requirements by on-site measurements taken prior to fabrication.



PL-01

Manufacturer to provide template to coordinate fabrication of top and base. All pieces to be mechanically secured together. Provide all corrosion proof hardware to secure pieces together.

Provide one pair side-mounted, ball bearing action, full extension drawer glides (accuride or equal) per drawer/tray.

Provide heavy-duty adjustable levelers.



Hardware Finish

Unless Using A Specified Manufacturer, Submit The Following Required Item(s) for Approval Prior to Fabrication:

Finish Sample **Shop Drawing**

Manufacturer to confirm the Product meets Hilton Design and Construction Standards as noted in Section 2515.00

Instructions:

- All quantities to be verified by hotel operator prior to purchasing.
- It is the responsibility of the owner to interpret these specifications for each property.
- All interpretations of the specification MUST be submitted to Hilton Design Review (projecthub.hilton.com) for final approval prior to purchasing or implementation of any material.
- Must be of contract quality and suitable for commercial use.
- All materials and methods of construction must comply with all local fire and life safety codes and Brand Standards.



Project Name: Home2 Prototype FF&E Specifications

Scheme: B-Dynamic

Issue Date: March-23

Revisions:

Item Number: **(B) PA-807**

Item Name: Three Bay Meeting Room
Casework

Area Name: Public Area - Meeting Room

-
- Manufacturer to provide all necessary hardware for each item. All internal hardware (hinges, screws, bolts, etc.) shall be corrosion proof.
 - Major joints as needed shall utilize lap joints or double doweled construction with corner blocks. Glue and staples are used to reinforce the joinery.
 - Metal fasteners should be used where appropriate to ensure commercial frame strength.
 - Manufacturer to verify all necessary parts, hardware and dimensions required for assembly.
 - All wood to be kiln dried and treated to be insect and vermin free.
 - Ensure that all pieces will fit in elevators and through doors prior to commencing fabrication.
 - Show all pieces in shop drawings. Provide reproducible scaled shop drawings to Hotel Operator Representative prior to production.
 - Provide clear alcohol and water-resistant penetrating sealer as required at wood.
 - Solid hardwood frames to be certified sustainable sources. All stress joints to be connected by double doweled, screwed and glued corner reinforcement.
 - All corners of metal frame to be mitered; All welds to be filled and fully finished; Grind and smooth all edges; No visible welds, seams, or burn marks; Seal as required.
 - Finish goods containing composite wood products must comply with California Code of Regulations 93120. Product and carton will be labeled in accordance with this regulation.
 - Manufacturer to clearly mark each carton with item ID and specification number.

Index

Project Name: Home2 FF&E Renovation Specs
 Scheme: Dynamic-Scheme A
 Area: Public Area

Issue Date	Revision #	Item Number	Item Description
------------	------------	-------------	------------------

Seating

05/01/23		(B) PA-150	Re-Upholstered Banquette - RENO ONLY
----------	--	------------	---

Lighting

05/01/23		(B) PA-250	Lamp @ Perch Table - RENO ONLY
----------	--	------------	---------------------------------------

Casegoods

05/01/23	Δ2	(B) PA-350	Printer Console - RENO ONLY
05/01/23	Δ2	(B) PA-351	Printer Station- Small - RENO ONLY

Window Treatment

05/01/23		(B) PA-450	Breakfast Drapery - RENO ONLY
----------	--	------------	--------------------------------------

Artwork & Mirrors

Outdoor

Millwork

05/01/23	Δ2	(B)PA-850	Reno Perch Table Small- RENO ONLY
05/01/23	Δ2	(B)PA-851	Reno Perch Table Large- RENO ONLY



Project Name: Home2 Prototype FF&E Specifications
 Scheme: B-Dynamic
 Issue Date: May-23
 Revisions:

Item Number: **(B) PA-150**
 Item Name: Re-upholstered Banquette
 Area Name: Public Area - Lobby
RENO ONLY

Manufacturer: **Custom**
 Address:

Phone:
 Contact:
 E-mail:
 Web:

Description: Re-upholstered Banquette @ Lobby Area
 Material/Finish: COM
 Overall Dimensions: 222"W 68"D 44"H
 Arm Height: NA
 Seat Height: 20"
 Seat Depth: 21"
 Seat Cushion Style: Match existing
 Back Cushion Style: Match existing
 Cushion Content: Tight with inner spring construction (seat only)
 Double needle stitching
 2.2 high density foam with 24-32 ILD rating



Back COM: Manufacturer: P Kaufmann Contract
 Phone: 646-593-2914
 Contact: Emily Mann
 emann@pkaufmann.com
 Pixel
 Color: 004M Sonoma
 Finish: SSR
 Fire Rating: CAL 117-2013 NFPA 260
 Content: 94% Polyester, 6% modacrylic
 Width: 54"

Email:
 Pattern:



Back

Seat COM: Manufacturer: Fil-Doux
 Phone: 212-202-1459
 Contact: Mirna Ramirez
 mirna@fildoux.com
 Color: Denim SKU110132
 Finish: Pro-Tech
 Fire Rating: CAL 117-2013 NFPA 260 Class 1, IMO Inherent
 Content: 100% Otratex
 Width: 54"
 Repeat: NA
 Double Rubs: 200,000
 Backing: 100% Recycled polyester knit
 Railroad: No

Email:
 Pattern: Brussels



Seat

Notes: Only upholstery to be replaced, all other finishes to remain. All pieces to be mechanically secured together.



Project Name: Home2 Prototype FF&E Specifications
Scheme: B-Dynamic
Issue Date: May-23
Revisions:

Item Number: **(B) PA-150**
Item Name: Re-upholstered Banquette
Area Name: Public Area - Lobby
RENO ONLY

Unless Using A Specified Manufacturer, Submit The Following Required Item(s) for Approval Prior to Fabrication:

Finish Sample **Cutting** **Shop Drawing**

Manufacturer to confirm the Product meets Hilton Design and Construction Standards as noted in Section 2515.00

Instructions:

- All quantities to be verified by hotel operator prior to purchasing.
- It is the responsibility of the owner to interpret these specifications for each property.
- All interpretations of the specification MUST be submitted to Hilton Design Review (projecthub.hilton.com) for final approval prior to purchasing or implementation of any material.
- Must be of contract quality and suitable for commercial use.
- COM quantities must be verified by fabricator prior to ordering.
- All materials and methods of construction must comply with all local fire and life safety codes for use in hotels and other public spaces, and Home2 Brand Standards.
- All internal hardware (hinges, screws, bolts, etc.) shall be corrosion proof.
- Wood frames to be certified sustainable sources. All stress joints to be connected by double doweled, screwed and glued corner reinforcement.
- Manufacturer to provide nylon carpet glides when applicable.
- All foam, batting, padding, and Dacron wrap shall be fire retardant to meet all applicable codes.
- Cushions to be adequately vented for displacement of air and to provide increased comfort.
- Ensure that upholstered goods will fit in elevators and through doors prior to commencing fabrication.
- Entire frame and upholstery shall be inspected during the manufacturing and again after final assembly. Tailoring shall be neat, trim and performed in a professional manner.
- Manufacturer to clearly mark each carton with item ID and specification number.
- Manufacturer to verify all necessary parts, hardware with each item.
- Reference the Design Intent softgood drawings on designinformation.hilton.com for further information.



Project Name: Home2 Prototype FF&E Specifications
Scheme: B-Dynamic
Issue Date: May-23
Revisions:

Item Number: **(B) PA-250**
Item Name: Lamp @ Perch Table
Area Name: Public Area - Lobby
RENO ONLY

Manufacturer: **Trinity Lighting**
Address: 2902 Quality Way
Jonesboro, AR 72401
Phone: 870-972-1177
Contact: Jennifer Williams
E-mail: jwilliams@trinitylighting.com
Web: www.trinitylighting.com

Description: Lamp at Perch Table
Overall Dimensions: 12"W x 14"H x 3"D
Finish: Powdercoated stainless steel exterior to match Benjamin Moore Blue Hydrangea #2062-60 matte finish
Switch Type: On/Off Accessible rocker base switch at base. Finish: Black
Cord Length: 120"
Cord Color: Clear/Silver
Plug Type: 90°/Right angle plug
Lamp Type: LED, PL, E26 Medium Socket 2700K
Lamp Wattage: 6W
Lamp Quantity: 1
UL Listing: Fixture must be U.L. listed and so labeled
Shade/Diff. Material: Powdercoated stainless steel shade to match Benjamin Moore Blue Hydrangea #2062-60 matte finish with frosted white acrylic diffuser
Shade/Diff. Dims.: 3"W x 10 1/2"L
Lamp Base: Base to feature felt protective non-skid padding secured to bottom. Base to be weighted.
Dimmer: No
Notes: To have two USB outlets



Metal Finish

Manufacturer to confirm the Product meets Hilton Design and Construction Standards as noted in Section 2515.00

Instructions:

- All quantities to be verified by hotel operator prior to purchasing.
- It is the responsibility of the owner to interpret these specifications for each property.
- All interpretations of the specification MUST be submitted to Hilton Design Review (projecthub.hilton.com) for final approval prior to purchasing or implementation of any material.
- Must be of contract quality and suitable for commercial use.
- All materials and methods of construction must comply with all local fire and life safety codes and Brand Standards.
- Fixture must be U.L. Listed and so labeled. Manufacturer is responsible for submitting all technical specifications for fire safety, UL standards, and any other specifications that are required to comply with local and state fire codes.
- Manufacturer/Fabricator to confirm weight of fixture.
- Show all pieces in scaled shop drawings. Entire fixture shall be inspected during the manufacturing and again after final assembly.
- Manufacturer to clearly mark each carton with item ID and specification number.

Project Name: Home2 Prototype FF&E Specifications
 Scheme: B-Dynamic
 Issue Date: May-23
 Revisions: June-23 Δ2

Item Number: **(B) PA-350**
 Item Name: Printer Console
 Area Name: Public Area - Lobby
RENO ONLY

Manufacturer: **Elkay Interior Systems**
 Address: 1 Mid America Plaza, Floor 3
 Oakbrook Terrace, IL 60181
 Phone: 414-224-0957
 Contact: Courtney Messersmith
 E-mail: hospitalitybids@elkayinteriorsystems.com
 Web: www.elkayinteriorsystems.com

Description: Print Station with Two Drawers
 Dimensions: 48"W X 24"D x 34"H
 Printer Cavity: 20"H x 22.5"W
 Top Thickness: 2CM
 Edge Detail: Square with eased edge
 Top Material/Finish: Quartz top, Finish to match ST-01 Daltile One Quartz - Simply White Polished with square, eased edges.
 Base Material/Finish: Plastic Laminate, Finish to match PL-01 Wilsonart 5th Ave Elm 7966K 12 Soft Grain Texture with Aeon; Leg Finish To match TIGER Drylac Sparkle Silver Glossy 49/90450
 Hardware: Pulls: Manzoni Hardware #MT0337-203-GSN (Satin Nickel) or approved eq.
 Finish: To match TIGER Drylac Sparkle Silver Glossy 49/90450
 Dimensions: 8 3/4"L x 1-1/8"D x 3/8"W
 Note: Pulls must be ADA compliant
 Glides: Knappe & Vogt 8450
 Data/Electrical: NA
 Notes: Manufacturer to verify size requirements by on-site measurements taken prior to fabrication.
 Manufacturer to provide template to coordinate fabrication of top and base. All pieces to be mechanically secured together. Provide all corrosion proof hardware to secure pieces together.
 Provide one pair side-mounted, ball bearing action, full extension drawer glides (accuride or equal) per drawer/tray.
 Provide heavy-duty adjustable levelers.

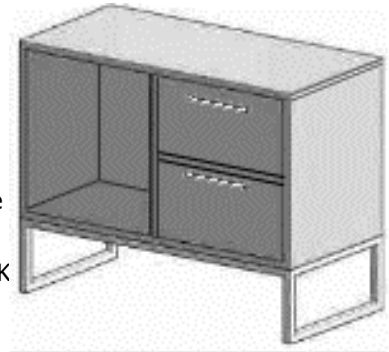

ST-01



PL-01



Hardware Finish

Unless Using A Specified Manufacturer, Submit The Following Required Item(s) for Approval Prior to Fabrication:
Finish Sample **Shop Drawing**

Manufacturer to confirm the Product meets Hilton Design and Construction Standards as noted in Section 2515.00



Project Name: Home2 Prototype FF&E Specifications
Scheme: B-Dynamic
Issue Date: May-23
Revisions: June-23 Δ2

Item Number: **(B) PA-350**
Item Name: Printer Console
Area Name: Public Area - Lobby
RENO ONLY

Instructions:

- All quantities to be verified by hotel operator prior to purchasing.
- It is the responsibility of the owner to interpret these specifications for each property.
- All interpretations of the specification **MUST** be submitted to Hilton Design Review (projecthub.hilton.com) for final approval prior to purchasing or implementation of any material.
- Must be of contract quality and suitable for commercial use.
- All materials and methods of construction must comply with all local fire and life safety codes and Brand Standards.
- Manufacturer to provide all necessary hardware for each item. All internal hardware (hinges, screws, bolts, etc.) shall be corrosion proof.
- Major joints as needed shall utilize lap joints or double doweled construction with corner blocks. Glue and staples are used to reinforce the joinery.
- Metal fasteners should be used where appropriate to ensure commercial frame strength.
- Manufacturer to verify all necessary parts, hardware and dimensions required for assembly.
- All wood to be kiln dried and treated to be insect and vermin free.
- Ensure that all pieces will fit in elevators and through doors prior to commencing fabrication.
- Show all pieces in shop drawings. Provide reproducible scaled shop drawings to Hotel Operator Representative prior to production.
- Provide clear alcohol and water-resistant penetrating sealer as required at wood.
- Solid hardwood frames to be certified sustainable sources. All stress joints to be connected by double doweled, screwed and glued corner reinforcement.
- All corners of metal frame to be mitered; All welds to be filled and fully finished; Grind and smooth all edges; No visible welds, seams, or burn marks; Seal as required.
- Finish goods containing composite wood products must comply with California Code of Regulations 93120. Product and carton will be labeled in accordance with this regulation.
- Manufacturer to clearly mark each carton with item ID and specification number.

Project Name: Home2 Prototype FF&E Specifications
 Scheme: B-Dynamic
 Issue Date: May-23
 Revisions: June-23 Δ2

Item Number: **(B) PA-351**
 Item Name: Printer Station
 Area Name: Public Area - Lobby
RENO ONLY

Manufacturer: **Elkay Interior Systems**
 Address: 1 Mid America Plaza, Floor 3
 Oakbrook Terrace, IL 60181
 Phone: 414-224-0957
 Contact: Courtney Messersmith
 E-mail: hospitalitybids@elkayinteriorsystems.com
 Web: www.elkayinteriorsystems.com

Description: Print Station with One Drawer
 Dimensions: 24.5"W X 24"D x 34"H
 Printer Cavity: 20"H x 22.5"W
 Top Thickness: 2CM
 Edge Detail: Square with eased edge
 Top Material/Finish: Quartz top, Finish to match ST-01 Daltile One Quartz - Simply White Polished with square, eased edges.
 Base Material/Finish: Plastic Laminate, Finish to match PL-01 Wilsonart 5th Ave Elm 7966K-12 Soft Grain Texture with Aeon;
 Hardware: Pulls: Manzoni Hardware #MT0337-203-GSN (Satin Nickel) or approved eq.
 Finish: To match TIGER Drylac Sparkle Silver Glossy 49/90450
 Dimensions: 8 3/4"L x 1-1/8"D x 3/8"W
 Note: Pulls must be ADA compliant
 Glides: Knap & Vogt 8450
 Data/Electrical: NA
 Notes: Manufacturer to verify size requirements by on-site measurements taken prior to fabrication.
 Manufacturer to provide template to coordinate fabrication of top and base. All pieces to be mechanically secured together. Provide all corrosion proof hardware to secure pieces together.
 Provide one pair side-mounted, ball bearing action, full extension drawer glides (accuride or equal) per drawer/tray.
 Provide heavy-duty adjustable levelers.



ST-01



PL-01



Hardware Finish

Unless Using A Specified Manufacturer, Submit The Following Required Item(s) for Approval Prior to Fabrication:

Finish Sample **Shop Drawing**

Manufacturer to confirm the Product meets Hilton Design and Construction Standards as noted in Section 2515.00



Project Name: Home2 Prototype FF&E Specifications
Scheme: B-Dynamic
Issue Date: May-23
Revisions: June-23 Δ2

Item Number: **(B) PA-351**
Item Name: Printer Station
Area Name: Public Area - Lobby
RENO ONLY

Instructions:

- All quantities to be verified by hotel operator prior to purchasing.
- It is the responsibility of the owner to interpret these specifications for each property.
- All interpretations of the specification **MUST** be submitted to Hilton Design Review (projecthub.hilton.com) for final approval prior to purchasing or implementation of any material.
- Must be of contract quality and suitable for commercial use.
- All materials and methods of construction must comply with all local fire and life safety codes and Brand Standards.
- Manufacturer to provide all necessary hardware for each item. All internal hardware (hinges, screws, bolts, etc.) shall be corrosion proof.
- Major joints as needed shall utilize lap joints or double doweled construction with corner blocks. Glue and staples are used to reinforce the joinery.
- Metal fasteners should be used where appropriate to ensure commercial frame strength.
- Manufacturer to verify all necessary parts, hardware and dimensions required for assembly.
- All wood to be kiln dried and treated to be insect and vermin free.
- Ensure that all pieces will fit in elevators and through doors prior to commencing fabrication.
- Show all pieces in shop drawings. Provide reproducible scaled shop drawings to Hotel Operator Representative prior to production.
- Provide clear alcohol and water-resistant penetrating sealer as required at wood.
- Solid hardwood frames to be certified sustainable sources. All stress joints to be connected by double doweled, screwed and glued corner reinforcement.
- All corners of metal frame to be mitered; All welds to be filled and fully finished; Grind and smooth all edges; No visible welds, seams, or burn marks; Seal as required.
- Finish goods containing composite wood products must comply with California Code of Regulations 93120. Product and carton will be labeled in accordance with this regulation.
- Manufacturer to clearly mark each carton with item ID and specification number.



Project Name:	Home2 Prototype FF&E Specifications	Item Number:	(B) PA-450
Scheme:	B-Dynamic	Item Name:	Breakfast Drapery
Issue Date:	May-23	Area Name:	Public Area
Revisions:			RENO ONLY

Manufacturer:	EE Sewing	Fabtex	Hunter Douglas Hospitality	Standard Textile
Address:	21601 E 340 Road Chelsea, Oklahoma 74016	29 Woodbine Lane Danville, PA 17821	12975 Brookprinter Place, Ste 210 Poway, CA 92064	One Knollcrest Dr Cincinnati, Ohio 45237
Phone:	918-789-5881	800-778-2791 x738	571-239-2746	410-484-5836
Contact:	Luke Cowles	Eric Frantz	Lindsey Malone	Jerry Katz
E-mail:	ee@junct.com	eric.frantz@fabtex.com	lindsey@jcfgroup.net	jkatz@standardtextile.com
Web:	www.eesewing.com	www.fabtex.com	www.hunterdouglas.com	www.standardtextile.com

Description: Drapery Panels at Breakfast Area

Ceiling Height: Typically 8'-10"

Opening Size: 26'-0"W x 8'-0"H, VIF

Mounting Method: Ceiling Mounted

Hardware: Size: 3/4" x 3/4"

Panels Style: Ripple Fold, 2-way draw, 160% Fullness

Panel Dimensions: (2) 13-0" W X 8'-0" L, varies - VIF

Finished Length: 1" AFF

Hemming: 1" single side hems; 4" double bottom hem. Pattern match all seams. Fabricated with a rolled hem and continuous shot tape to create even weight and drape.

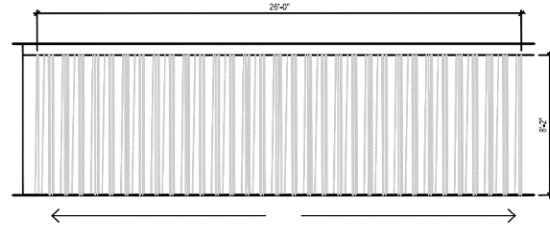
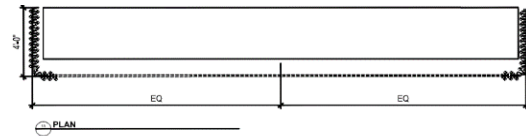

COM/COL: Pattern must be on both sides of fabric
 Manufacturer: P/Kaufmann
 Pattern: Merino
 Color: Merlot
 Fabric Content: 100% Polyester
 Width: 57"
 Fire Ratings: NFPA-701

Notes: Manufacturer to verify all opening sizes and fabric requirements prior to fabrication.
 Manufacturers to provide fascia to cove roll (fascia finish to match meal window frame).
 Drapery installer to field verify existing hardware and track is suitable for reuse. If not, use match previous specified track.

Unless Using A Specified Manufacturer, Submit The Following Required Item(s) for Approval Prior to Fabrication:

Cutting **Shop Drawing** **Flame Certificate**

Manufacturer to confirm the Product meets Hilton Design and Construction Standards as noted in Section 2515.03

Instructions:

- All quantities to be verified by hotel operator prior to purchasing.
- It is the responsibility of the owner to interpret these specifications for each property.
- All interpretations of the specification MUST be submitted to Hilton Design Review (projecthub.hilton.com) for final approval prior to purchasing or implementation of any material.
- Must be of contract quality and suitable for commercial use.
- COM quantities must be verified by fabricator prior to ordering.
- All materials and methods of construction must comply with all local fire and life safety codes for use in hotels and other public spaces, and Brand Standards.
- All quantity requirements must be verified by on-site measurements taken prior to fabrication.
- Drapery fabricator to provide all hardware complete for installation.



Project Name:	Home2 Prototype FF&E Specifications	Item Number:	(B) PA-450
Scheme:	B-Dynamic	Item Name:	Breakfast Drapery
Issue Date:	May-23	Area Name:	Public Area
Revisions:			RENO ONLY

- Drapery fabricator is responsible for the size and quantity of all hardware to be used.
- Draperies must meet Class 1 ASTM E-84 and NFPA 701 Small and Large Scale as required by local and state fire codes for use in hotels.
- Manufacturer to clearly mark each carton with item ID and specification number.
- Sheer treatments must have a 1" single side hem, 4" single heading and 4" double bottom hem. Blackout treatments must have a 1" single side hem, 4" single heading and 1/2" double bottom hem.
- Sheer and blackout must have 1/2" clear front mounted baton that is 48" AFF.



Project Name: Home2 Prototype FF&E Specifications
 Scheme: B-Dynamic
 Issue Date: May-23
 Revisions:

Item Number: **(B) PA-550**
 Item Name: Printer Station Artwork
 Area Name: Public Area - TV Lounge
RENO ONLY

Manufacturer:	Kalisher	PI Fine Art	Wendover Art Group
Address:	800 Taylor Street, Suite 9A-154 Durham, NC 27701	1180 Caledonia Road Toronto, Ontario M6A 2W5	6465 126th Ave N Largo, Florida 33773
Phone:	919-967-4300 x123	416-789-7156 x255	727-573-1417
Contact:	Claire Sugg	Elise Vandebosch	Carmine Giso
E-mail:	c.sugg@kalisher.com	hilton@pifineart.com	hilton@wendoverart.com
Web:	www.kalisher.com	www.pifineart.com	www.wendoverart.com

Description: Framed Print @ TV Lounge
 Dimensions: 36"W x 36" H
 Molding Number: Michelangelo 41-29
 Molding Width: 1 1/4"W x 1 1/8"H
 Finish: Michelangelo Avant-Garde 41-29
 Orientation: Vertical
 Mounting Height: See architectural drawings
 Hardware: 3 Point Security Hardware
 Notes: See Design Guide for artwork content requirements.



Unless Using A Specified Manufacturer, Submit The Following Required Item(s) for Approval Prior to Fabrication:
Finish Sample **Shop Drawing**

Manufacturer to confirm the Product meets Hilton Design and Construction Standards as noted in Section 2515.05

Instructions:

- All quantities to be verified by hotel operator prior to purchasing.
- It is the responsibility of the owner to interpret these specifications for each property.
- All interpretations of the specification MUST be submitted to Hilton Design Review (projecthub.hilton.com) for final approval prior to purchasing or implementation of any material.
- Must be of contract quality and suitable for commercial use.
- All materials and methods of construction must comply with all local fire and life safety codes for use in hotels and other public spaces, and Brand Standards.
- Manufacturer to provide all component parts for complete assembly and installation.
- Mounting method to be sufficient for weight of piece.
- All pieces must be crated for shipping. All corners should be wrapped with corner guards. Crates should be labeled with instructions for shipment, storage and opening of crate.
- Manufacturer to provide 3-point or continuous cleat security cleating system appropriate for the size and weight of the artwork.
- Manufacturer to clearly mark each carton with item ID and specification number.
- Provide 1/4" (6mm) backer sheet, gator foam or tempered Masonite.
- Wood frames to be certified sustainable sources. All stress joints to be connected by double doweled, screwed and glued corner reinforcement.
- Must adhere to CARB Title 17 Standards: formaldehyde emissions for hardwood plywood, particleboard, and medium density fiberboard may not exceed .05ppm.



Project Name: Home2 Prototype FF&E Specifications

Scheme: B-Dynamic

Issue Date: May-23

Revisions:

Item Number: **(B) PA-550**

Item Name: Printer Station Artwork

Area Name: Public Area - TV Lounge

RENO ONLY

-
- Finish goods containing composite wood products must comply with California Code of Regulations 93120. Product and carton will be labeled in accordance with this regulation.

Project Name: Home2 Prototype FF&E Specifications
 Scheme: B-Dynamic
 Issue Date: May-23
 Revisions: June-23 Δ2

Item Number: **(B) PA-850**
 Item Name: Perch Table - Small
 Area Name: Public Area - Lobby & Fitness
RENO ONLY

Manufacturer: **Elkay Interior Systems**
 Address: 1 Mid America Plaza, Floor 3
 Oakbrook Terrace, IL 60181
 Phone: 414-224-0957
 Contact: Courtney Messersmith
 E-mail: hospitalitybids@elkayinteriorsystems.com
 Web: www.elkayinteriorsystems.com

Description: Counter-height Window Perch @ Lobby
 Style: Window perch with HPL top with PVC edge banding and steel supports (34" H counter to meet ADA Guideline Standards)
 Width: 72" Verify in Field
 Depth: 21"
 Height: 34"
 Top Material/Finish: Plastic Laminate, Finish to match PL-01 Wilsonart 5th Ave Elm 7966K-12 Soft Grain Texture with Aeon
 Edge Detail: 2 mm edgebanding to match PL-01 Wilsonart 5th Ave Elm 7966K-12 Soft Grain Texture with Aeon
 Base Material/Finish: Steel, powder-coated to match TIGER Drylac Sparkle Silver Glossy 49/90450
 Wire Manager: Z Clips: Doug Mockett VM28/2IN-90
 Power Supply: 1 Byrne Electrical Burele (or equal) with 2 outlets and 2 sets of charging USB, black finish - 15-0" power cord
 Notes: Manufacturer to verify size requirements by on-site measurements taken prior to fabrication.
 Manufacturer to provide template to coordinate fabrication of top and base. All pieces to be mechanically secured together. Provide all corrosion proof hardware to secure pieces together.
 Provide heavy duty adjustable nylon glides.

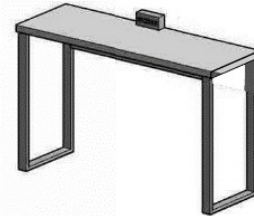

PL-01



Metal Finish

Unless Using A Specified Manufacturer, Submit The Following Required Item(s) for Approval Prior to Fabrication:

Finish Sample **Shop Drawing**

Manufacturer to confirm the Product meets Hilton Design and Construction Standards as noted in Section 2515.00

Instructions:

- All quantities to be verified by hotel operator prior to purchasing.
- It is the responsibility of the owner to interpret these specifications for each property.
- All interpretations of the specification MUST be submitted to Hilton Design Review (projecthub.hilton.com) for final approval prior to purchasing or implementation of any material.
- Must be of contract quality and suitable for commercial use.
- All materials and methods of construction must comply with all local fire and life safety codes and Brand Standards.
- Manufacturer to provide all necessary hardware for each item. All internal hardware (hinges, screws, bolts, etc.) shall be corrosion proof.



Project Name: Home2 Prototype FF&E Specifications
Scheme: B-Dynamic
Issue Date: May-23
Revisions: June-23 Δ2

Item Number: **(B) PA-850**
Item Name: Perch Table - Small
Area Name: Public Area - Lobby & Fitness
RENO ONLY

- Major joints as needed shall utilize lap joints or double doweled construction with corner blocks. Glue and staples are used to reinforce the joinery.
- Metal fasteners should be used where appropriate to ensure commercial frame strength.
- Manufacturer to verify all necessary parts, hardware and dimensions required for assembly.
- All wood to be kiln dried and treated to be insect and vermin free.
- Ensure that all pieces will fit in elevators and through doors prior to commencing fabrication.
- Show all pieces in shop drawings. Provide reproducible scaled shop drawings to Hotel Operator Representative prior to production.
- Provide clear alcohol and water-resistant penetrating sealer as required at wood.
- Solid hardwood frames to be certified sustainable sources. All stress joints to be connected by double doweled, screwed and glued corner reinforcement.
- All corners of metal frame to be mitered; All welds to be filled and fully finished; Grind and smooth all edges; No visible welds, seams, or burn marks; Seal as required.
- Finish goods containing composite wood products must comply with California Code of Regulations 93120. Product and carton will be labeled in accordance with this regulation.
- Manufacturer to clearly mark each carton with item ID and specification number.

Project Name: Home2 Prototype FF&E Specifications
 Scheme: B-Dynamic
 Issue Date: May-23
 Revisions: June-23 Δ2

Item Number: **(B) PA-851**
 Item Name: Perch Table - Large
 Area Name: Public Area - Lobby
RENO ONLY

Manufacturer: **Elkay Interior Systems**
 Address: 1 Mid America Plaza, Floor 3
 Oakbrook Terrace, IL 60181
 Phone: 414-224-0957
 Contact: Courtney Messersmith
 E-mail: hospitalitybids@elkayinteriorsystems.com
 Web: www.elkayinteriorsystems.com

Description: Counter-height Window Perch @ Lobby
 Style: Window perch with HPL top with PVC edge banding and steel supports (34" H counter to meet ADA Guideline Standards)

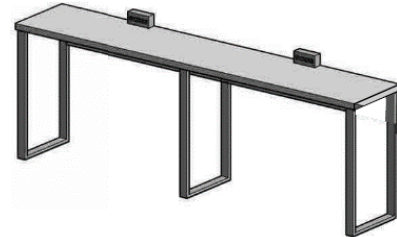

Width: 99" Verify in Field
 Depth: 21"
 Height: 34"

Top Material/Finish: Plastic Laminate, Finish to match PL-01 Wilsonart 5th Ave Elm 7966K-12 Soft Grain Texture with Aeon

Edge Detail: 2 mm edgebanding to match PL-01 Wilsonart 5th Ave Elm 7966K-12 Soft Grain Texture with Aeon

Base Material/Finish: Steel, powder-coated to match TIGER Drylac Sparkle Silver Glossy 49/90450

Wire Manager: Z Clips: Doug Mockett VM28/2IN-90

Power Supply: 2each Byrne Electrical Burele (or equal) with 2 outlets and 2 sets of charging USB, black finish - 15-0" power cord

Notes: Manufacturer to verify size requirements by on-site measurements taken prior to fabrication.

Manufacturer to provide template to coordinate fabrication of top and base. All pieces to be mechanically secured together. Provide all corrosion proof hardware to secure pieces together.

Provide heavy duty adjustable nylon glides.



PL-01



Metal Finish

Unless Using A Specified Manufacturer, Submit The Following Required Item(s) for Approval Prior to Fabrication:

Finish Sample **Shop Drawing**

Manufacturer to confirm the Product meets Hilton Design and Construction Standards as noted in Section 2515.00

Instructions:

- All quantities to be verified by hotel operator prior to purchasing.
- It is the responsibility of the owner to interpret these specifications for each property.
- All interpretations of the specification MUST be submitted to Hilton Design Review (projecthub.hilton.com) for final approval prior to purchasing or implementation of any material.
- Must be of contract quality and suitable for commercial use.
- All materials and methods of construction must comply with all local fire and life safety codes and Brand Standards.
- Manufacturer to provide all necessary hardware for each item. All internal hardware (hinges, screws, bolts, etc.) shall be corrosion proof.



Project Name: Home2 Prototype FF&E Specifications
Scheme: B-Dynamic
Issue Date: May-23
Revisions: June-23 Δ2

Item Number: **(B) PA-851**
Item Name: Perch Table - Large
Area Name: Public Area - Lobby
RENO ONLY

- Major joints as needed shall utilize lap joints or double doweled construction with corner blocks. Glue and staples are used to reinforce the joinery.
- Metal fasteners should be used where appropriate to ensure commercial frame strength.
- Manufacturer to verify all necessary parts, hardware and dimensions required for assembly.
- All wood to be kiln dried and treated to be insect and vermin free.
- Ensure that all pieces will fit in elevators and through doors prior to commencing fabrication.
- Show all pieces in shop drawings. Provide reproducible scaled shop drawings to Hotel Operator Representative prior to production.
- Provide clear alcohol and water-resistant penetrating sealer as required at wood.
- Solid hardwood frames to be certified sustainable sources. All stress joints to be connected by double doweled, screwed and glued corner reinforcement.
- All corners of metal frame to be mitered; All welds to be filled and fully finished; Grind and smooth all edges; No visible welds, seams, or burn marks; Seal as required.
- Finish goods containing composite wood products must comply with California Code of Regulations 93120. Product and carton will be labeled in accordance with this regulation.
- Manufacturer to clearly mark each carton with item ID and specification number.